

1. BID Agenda

Documents:

[2.9.2023 AGENDA.PDF](#)

2. BID PACKET

Documents:

[2.9.2023 PACKET.PDF](#)

MEETING AGENDA

BUSINESS IMPROVEMENT DISTRICT ADVISORY BOARD

THURSDAY, FEBRUARY 9, 2023 AT 8:30 A.M.

**COMMUNITY DEVELOPMENT DEPARTMENT BUILDING,
215 "D" STREET, SECOND FLOOR MEETING ROOM**

AS A MATTER OF PUBLIC SERVICE AND GOVERNMENTAL TRANSPARENCY, THIS MEETING MAY BE RECORDED, STREAMED LIVE AND/OR ACCESSED AT A LATER TIME. NOTE THAT THIS MAY INCLUDE VIDEO AND AUDIO OF ALL PERSONS PRESENT IN THE ROOM

Seating will be available on a first-come, first-served basis. All others who wish to observe this meeting may watch and listen to the livestream on their own device(s) by visiting the City of Lewiston's Facebook page or the City's website at cityoflewiston.org.

- I. **CALL TO ORDER**

- II. **CITIZEN COMMENTS** – An opportunity for citizens to address the Board with comments and/or questions. Citizens are asked to limit their time to three (3) minutes each. Comments and questions may be made by:
 - ✓ Attending in-person
 - ✓ Emailing comments and questions prior to the start of the meeting to khollingshead@cityoflewiston.org or dortiz@cityoflewiston.org
 - ✓ Mailing written comments prior to the start of the meeting to Katie Hollingshead, PO Box 617, Lewiston, ID 83501
 - ✓ Calling 208-746-1318 x7261 and leaving your message. Your comments will then be forwarded to the Business Improvement District Advisory Board.

- III. **APPROVAL OF JANUARY 12, 2023 MINUTES (ACTION ITEM)**

- IV. **REPORT ON FOUNDARY NEGOTIATIONS – W. PRICE/D. BAUER (ACTION ITEM)**

- V. **FINANCIALS – B. MORGAN (ACTION ITEM)**
 - A. Review of Bank Statement

B. Review of Invoices

- VI. DISCUSSION OF STRATEGIC PLAN FOR BID THROUGH CLOSURE ON 12-31-2026 (ACTION ITEM)**
- VII. REVIEW 2023 WORK PLAN AND BUDGET – B. MORGAN (ACTION ITEM)**
- A. Area #2 – Planters for Downtown from Wilbert Precast, cost sharing for transportation before starting bid process - UPDATE**
 - B. Area #3 – Banner Project sheet - UPDATE**
 - C. Area #3 - Town Hall meeting with Incite! Consulting on 5/9/23. Review and approve Memorandum of Understanding**
 - D. Soofa Signs**
- VIII. BOARD MEMBER COMMENTS**
- IX. STAFF COMMENTS**
Query of Board members to attend the regularly scheduled March 9, 2023 meeting.
- X. BID ADMINISTRATOR COMMENTS**
- XI. ADJOURN (ACTION ITEM)**

MEETING AGENDA

BUSINESS IMPROVEMENT DISTRICT ADVISORY BOARD

THURSDAY, FEBRUARY 9, 2023 AT 8:30 A.M.

**COMMUNITY DEVELOPMENT DEPARTMENT BUILDING,
215 "D" STREET, SECOND FLOOR MEETING ROOM**

AS A MATTER OF PUBLIC SERVICE AND GOVERNMENTAL TRANSPARENCY, THIS MEETING MAY BE RECORDED, STREAMED LIVE AND/OR ACCESSED AT A LATER TIME. NOTE THAT THIS MAY INCLUDE VIDEO AND AUDIO OF ALL PERSONS PRESENT IN THE ROOM

Seating will be available on a first-come, first-served basis. All others who wish to observe this meeting may watch and listen to the livestream on their own device(s) by visiting the City of Lewiston's Facebook page or the City's website at cityoflewiston.org.

- I. **CALL TO ORDER**

- II. **CITIZEN COMMENTS** – An opportunity for citizens to address the Board with comments and/or questions. Citizens are asked to limit their time to three (3) minutes each. Comments and questions may be made by:
 - ✓ Attending in-person
 - ✓ Emailing comments and questions prior to the start of the meeting to khollingshead@cityoflewiston.org or dortiz@cityoflewiston.org
 - ✓ Mailing written comments prior to the start of the meeting to Katie Hollingshead, PO Box 617, Lewiston, ID 83501
 - ✓ Calling 208-746-1318 x7261 and leaving your message. Your comments will then be forwarded to the Business Improvement District Advisory Board.

- III. **APPROVAL OF JANUARY 12, 2023 MINUTES (ACTION ITEM)**

- IV. **REPORT ON FOUNDARY NEGOTIATIONS – W. PRICE/D. BAUER (ACTION ITEM)**

- V. **FINANCIALS – B. MORGAN (ACTION ITEM)**
 - A. Review of Bank Statement

B. Review of Invoices**VI. DISCUSSION OF STRATEGIC PLAN FOR BID THROUGH CLOSURE ON 12-31-2026 (ACTION ITEM)****VII. REVIEW 2023 WORK PLAN AND BUDGET – B. MORGAN (ACTION ITEM)**

- A. Area #2 – Planters for Downtown from Wilbert Precast, cost sharing for transportation before starting bid process - UPDATE**
- B. Area #3 – Banner Project sheet - UPDATE**
- C. Area #3 - Town Hall meeting with Incite! Consulting on 5/9/23. Review and approve Memorandum of Understanding**
- D. Soofa Signs**

VIII. BOARD MEMBER COMMENTS**IX. STAFF COMMENTS**

Query of Board members to attend the regularly scheduled March 9, 2023 meeting.

X. BID ADMINISTRATOR COMMENTS**XI. ADJOURN (ACTION ITEM)**

January 12, 2023

THE BUSINESS IMPROVEMENT DISTRICT ADVISORY BOARD OF THE CITY OF LEWISTON, IDAHO, met at its regular meeting Thursday, January 12, 2023 at the Community Development Department Second Floor meeting room. The meeting was called to order at 8:32 a.m.

I. CALL TO ORDER AND INTRODUCTION

BOARD MEMBERS PRESENT: Wendy Price, Chair; Dr. Dennis Ohrtman, Vice Chair (via Zoom); Susie Jones; Tami Meyers; Michael Follett; Garry Bush (via zoom)

BOARD MEMBERS ABSENT: Doug Bauer;

STAFF MEMBERS PRESENT: Katie Hollingshead, Assistant City Planner; Dawn Ortiz, Community Development Specialist; Aaron Butler, IT; Melinda Rose, Grant Manager

OTHERS PRESENT: Brenda Morgan, Executive Director for Beautiful Downtown Lewiston (BDL)

II. PUBLIC COMMENTS

None.

III. ELECTION OF CHAIR AND VICE CHAIR FOR 2023 (ACTION ITEM)

Board member Ohrtman nominated Wendy Price for Chair. All Board members voted in favor of Wendy Price for Chair, 6-0.

Board member Ohrtman nominated Tami Meyers for Vice Chair. All Board members voted in favor of Tami Meyers for Vice Chair, 6-0.

IV. APPROVAL OF DECEMBER 8, 2022 MINUTES (ACTION ITEM)

Board members, Meyers and Follett moved and seconded, respectively, the approval of the December 8, 2022 meeting minutes. The motion carried 6-0.

V. BOARD APPROVAL TO ADD THE BUSINESS IMPROVEMENT DISTRICT ADVISORY BOARD CHAIR AS A SECOND SIGNER ON THE BID CHECKING ACCOUNT (ACTION ITEM)

Board member Bush asked if motion verbiage should include Vice-Chairperson in case the Chair is not available.

Assistant Planner Katie Hollingshead stated adding multiple people to the bank account is not ideal. There can always be a special meeting to change or add a different signer.

Board members, Meyers and Follett moved and seconded, respectively, to approve adding BID Chair as a second signer on the BID checking account. Motion passed 6-0.

VI. REPORT ON FOUNDARY NEGOTIATIONS – W. PRICE/D. BAUER (ACTION ITEM)

Chair Price stated at this point in time she and Board member Bauer have not had contact with the Foundary. They have gone and looked at the statues and feel they look great. They asked if there is someone to walk them through the blemishes so they have background and understanding when they do speak with the Foundary. They would feel better if a professional would help point out the items wrong with each statue.

Board member Ohrtman recommends having Sharon Taylor-Grant meet with Chair Price and Board member Bauer about the statues. Mr. Ohrtman will provide Chair Price with contact information for Mrs. Taylor-Grant.

VII. FINANCIALS – B. MORGAN (ACTION ITEM)

A. Review of Bank Statement

Brenda Morgan with Beautiful Downtown Lewiston stated there are no invoices for last month to approve and the Wells Fargo bank account has been completely closed out. Ms. Morgan is still working on moving the BID funds from P1FCU to another bank account.

Board member Follett asked what bank BDL is changing to.

Ms. Morgan stated she believes it is Idaho Central Credit Union.

VIII. DISCUSSION OF STRATEGIC PLAN FOR BID THROUGH CLOSURE ON 12-31-2026 (ACTION ITEM)

Ms. Morgan stated a strategic plan would provide an over view of the BID District. She would like to have opinions and discussion on what the strategic plans should look like.

Vice Chair Meyers asked if a work session would be best for this discussion?

Ms. Morgan stated a work session would be great. Come up with four years of a plan.

Chair Price would like to have a facilitator come in for the discussion like BDL had for one of their meetings.

Ms. Morgan stated another option would be to hire a consultant to come in and be the facilitator as well.

Vice Chair Meyers stated having a work session with a local facilitator.

Board member Ohrtman doesn't want the plan to have too many layers. The process should be very streamlined.

Staff Hollingshead stated breaking down the big picture into smaller tasks will be very helpful.

Ms. Morgan offered to reach out to other BID locations to see who they have for a liaison on this.

IX. REVIEW 2023 WORK PLAN AND BUDGET – B. MORGAN (ACTION ITEM)

A. Area #2 – Planters for Downtown from Wilbert Precast, cost sharing for transportation of planters before starting bid process

Ms. Morgan has been working with Parks and Recreation Director Tim Barker on the best process to replace the planters downtown. If the BID orders through Wilbert Precast they will be willing to do a cost-sharing on the delivery of the planters. Cement planters will be the most feasible option for downtown. There are currently 22 planters downtown and BDL has the ability to store 26, bulk pricing with Wilbert Precast starts at 30 planters. Ms. Morgan is trying to find additional storage and looking at where the additional planters can be placed, possibly on East Main. Parks and Rec will need to assist because they will need to install and run water to the planters. Until the road infrastructure is complete downtown, the water supply will have to be capped when the old planters are removed. By purchasing cement planters there is the option to fill them with dirt and flowers and move them when needed. The shipping cost per planter is \$500 versus \$130 if the BID does cost sharing with Wilbert Precast.

Board member Jones stated they have accounts with trucking companies and could assist with getting some quotes for getting the planters here. If Ms. Morgan could get her the information, she is willing to reach out to her contacts.

Board member Follett asked when road construction will start to happen. No board members or staff were sure when the construction would happen.

Staff Hollingshead stated BID could ask Director Johnson to come and speak to the board in regard to the projected road infrastructure construction on Main Street.

Ms. Morgan asked the board if they would like her to request a bid from Wilbert Precast.

Staff Hollingshead recommends tabling that request until Ms. Morgan gets with Board member Jones about the transportation of planters. Then bring bids from multiple locations.

B. Area #3 – Adding more banner hardware on Main Street (6), install new banner hardware on D Street (10) and printing banners for 5th Street (13 spaces)

Ms. Morgan asked the Board if they would like to invest in the hardware installation or printing more banners. BDL will cover what BID does not choose to purchase. Ms. Morgan stated that BDL is not allowed to list sponsors on their banners per the City of Lewiston.

Staff Hollingshead asked Ms. Morgan to provide where that direction came from so she can look into it and find the section of code.

Board member Ohrtman asked what the cost was to change the hanging banners out and who pays for it.

Staff Hollingshead stated it is possibly Public Works that does the change out, but she would have to follow up with them.

Board members, Meyers and Follett moved and seconded, respectively, to add banner hardware on Main Street and install new banner hardware on D Street, up to a total of 23. The motion carried 6-0.

C. Area #3 – Town Hall meeting with Incite! Consulting on 5/9/2023

A Memorandum of Understanding was not provided in this packet but will be provided at the next meeting. This agenda item will be added to next month's meeting.

Ms. Morgan provided a summary of what the MOU is for.

D. Area #4 – 3rd party Administrator for BID

Ms. Morgan has reached out to other Cities to see how they operate their BID districts. Multiple cities referred Ms. Morgan to Eide Bailly from Spokane as a 3rd party administrator.

Board member Ohrtman asked if BID would be paying Eide Bailly instead of BDL. Would that make an impact on BDL's budget?

Ms. Morgan stated the BID would pay Eide Bailly instead of BDL and it would not necessarily affect BDL's budget.

Staff Hollingshead asked Ms. Morgan to bring something back for the February meeting, that staff can then take back to the City of Lewiston's legal team. Fees are set by the resolution between the City of Lewiston and BDL. To change this resolution could be a large process and the Board will need to have all the pieces before making that decision. The last thing the Board needs is something like this to hinder projects from getting done.

Ms. Morgan stated she wanted to be transparent about all the options that the Board has.

X. BOARD MEMBER COMMENTS

Board member Follett stated the projects done so far are great, but need to get more people downtown. If the City of Lewiston could come up with an area for a food court that would really help downtown and draw a lot of people.

Chair Price stated that is a great discussion to have with someone who would be willing to take care of it.

Staff Hollingshead asked if Board member Follett was thinking of something permanent or event style.

Board member Follett stated something permanent would draw people on a regular basis.

Chair Price stated if Board member Follett had any contacts, he could send them to Vice Chair Meyers, and she would then be able to compile that information and possibly make it happen.

Ms. Morgan stated starting in February BDL is doing an event called "First Friday" and inviting every food truck. They will be launching the first one on February 3rd.

Board member Jones stated the Tri Cities just opened a very large one that is very nice. It was a brilliant idea that brings in a lot of people.

Board member Bush stated there is an issue with no signage in downtown Lewiston for historic markers. This is particularly a problem for the cruise ships bringing tourists to downtown. These tourists do not know how to get from one location to another.

Ms. Morgan stated she has a proposal to be on the February meeting agenda for an interactive sign that will be placed downtown with semi-permanent arrows that will be painted around downtown and color coded to match the interactive sign. Ms. Morgan asked if Board member Bush could provide the map handed out by the cruise ship.

XI. STAFF COMMENTS

A. Welcome to new Board Members

Staff Hollingshead welcomed new board members and reminder about February's meeting. If you are not able to attend or if you need a zoom link please let staff know.

XII. BID ADMINISTRATOR COMMENTS

A. Beautiful Downtown Lewiston's annual meeting on 2/7/2023

Ms. Morgan stated BDL's annual meeting will be at the Library from 5 to 7 pm on 2/7/2023. There will be a panel with Public Works, Community Development and Park and Recs directors. Would like to have BID members to participate as well.

XIII. ADJOURNMENT (ACTION ITEM)

There being no further business, Board members Follett and Meyers moved and seconded, respectively to adjourn. The motion carried 6-0 and the Business Improvement District adjourned at approximately 9:47 a.m.

RESPECTFULLY SUBMITTED,

ATTEST:

RECORDING SECRETARY

BID ADVISORY BOARD CHAIR

Approved this ____ day of _____, 2023.



PO Box 897 • Lewiston, ID 83501-0897
 (208) 746-8900 • (800) 843-7128 • p1fcu.org

Account # ****55

Page 1

BEAUTIFUL DOWNTOWN LEWISTON REVITALIZATI
 301 MAIN ST STE 103
 LEWISTON ID 83501-1819

Statement Date 12/31/2022

S0041 - BUSINESS IMPROVEMENT DISTRICT

Previous Balance	+	Deposits and Other Credits (2)	-	Withdrawals and Other Debits (6)	=	New Balance
\$119,256.49		\$14,279.83		\$-56,436.71		\$77,099.61

Trans Date	Eff Date	Transaction Description	Additions	Subtractions	Balance
12/01		Previous Balance			\$119,256.49
12/02	12/02	Draft 2501 Tracer 837200001063441.....		\$-15,643.50	\$103,612.99
12/07	12/07	Deposit by Check.....	\$14,268.71		\$117,881.70
12/09	12/09	Draft 2506 Tracer 837800001883987.....		\$-29,500.71	\$88,380.99
12/14	12/14	Draft 2503 Tracer 838400000515003.....		\$-3,875.00	\$84,505.99
12/14	12/14	Draft 2504 Tracer 838400000517501.....		\$-7,000.00	\$77,505.99
12/19	12/19	Draft 2502 Tracer 838900000583779.....		\$-375.00	\$77,130.99
12/28	12/28	Withdrawal ACH INTUIT * TYPE: QBooks Onl ID: 0000756346 CO: INTUIT * Entry Class Code: CCD.....		\$-42.50	\$77,088.49
12/31	12/31	Deposit Dividend 0.150%.....	\$11.12		\$77,099.61
		Annual Percentage Yield Earned: 0.150% For the 30 day period.....			
12/31		New Balance			\$77,099.61

EXPLANATION OF FINANCE CHARGES: The FINANCE CHARGE for a loan is made up of two parts: (1) interest, and (2) certain other fees. To compute the finance charge, the unpaid balance for each day since your last payment (or since an advance if have not yet made a payment) is multiplied by the applicable daily periodic rate.

Insured
by NCUA





Final Details for Order #111-2441868-3559450

[Print this page for your records.](#)

Order Placed: January 26, 2023

Amazon.com order number: 111-2441868-3559450

Order Total: \$475.00

Shipped on January 27, 2023

Items Ordered

Price

1 of: *Plasticade 140NSBKBOXED Signicade Deluxe A-Frame Sidewalk Curb Sign Portable* \$439.00
Folding Double-Sided Display with Quick-Change System, White (4 Pack)

Sold by: Signs Direct ([seller profile](#))

Dinner in the Dark Event Supplies

Condition: New

Shipping Speed:

Standard Shipping

Payment information

Payment Method:

Visa | Last digits: 7039

Item(s) Subtotal: \$439.00

Shipping & Handling: \$0.00

Billing address

Brenda Morgan
301 MAIN ST STE 103
LEWISTON, ID 83501-1819
United States

Total before tax: \$439.00

Estimated tax to be collected: \$36.00

Grand Total: \$475.00

Credit Card transactions

Visa ending in 7039: January 27, 2023: \$475.00

To view the status of your order, return to [Order Summary](#).



amazon smile

Final Details for Order #111-8419749-5595406

[Print this page for your records.](#)

Order Placed: January 4, 2023
Amazon.com order number: 111-8419749-5595406
Order Total: \$194.72

Shipped on January 5, 2023

Items Ordered

2 of: *Trademark Innovations Miniature Indoor Desktop Bean Bag Toss Cornhole Game - 10 1/4" x 15 1/2"* **Price**
Sold by: Amazon.com Services LLC **\$34.52**

Dinner in the Dark Event Supplies

Condition: New

Shipping Speed:

Standard Shipping

Shipped on January 8, 2023

Items Ordered

2 of: *Boao 12 Packs Mini Clear Acrylic Easel Stands Coin Display Easel, 2.25 Inch Tall* **Price**
Sold by: BoaoNetwork ([seller profile](#)) | Product question? [Ask Seller](#) **\$10.99**

Condition: New

1 of: *20 x 2.3 Ft Neoprene Red Carpet Runner Reusable Red Plastic Floor Runner Non-Slip Rubber Backed Runner Rugs for Hallway Red Aisle Runner Carpet Roll for Wedding Party Decoration Prom Business Outdoor* **\$62.99**

Sold by: Waydress ([seller profile](#)) | Product question? [Ask Seller](#)

Dinner in the Dark Event Supplies

Condition: New

1 of: *Walden Farms 5 Pack Variety Coffee Creamer, 12 oz Bottles, Fresh Flavored Non-Dairy Milk Substitute, Natural and Liquid, Gluten Free and 0g Net Carbs, Vegan Friendly, Sweet Cream, French Vanilla, Original Cream, Hazelnut, Mocha* **\$31.49**

Sold by: The Market Space ([seller profile](#))

Condition: New

Shipping Speed:

Standard Shipping

Payment information

Payment Method:

Visa | Last digits: 7039

Billing address

Brenda Morgan
301 MAIN ST STE 103
LEWISTON, ID 83501-1819
United States

Credit Card transactions

Item(s) Subtotal: \$185.50
Shipping & Handling: \$0.00
Your Coupon Savings: -\$3.15

Total before tax: \$182.35
Estimated tax to be collected: \$12.37

Grand Total: \$194.72

-\$42.48

\$97.39

To view the status of your order, return to [Order Summary](#).



Final Details for Order #111-6094809-5057056

[Print this page for your records.](#)

Order Placed: January 4, 2023
Amazon.com order number: 111-6094809-5057056
Order Total: \$162.29

Shipped on January 4, 2023

Items Ordered	Price
1 of: <i>Mophorn 6PCS Stanchion Queue Post, Black 6.5ft Retractable Belt 36In Height, Stanchion Posts Queue Pole for Crowd Control Barriers</i>	\$149.99
Sold by: Mophorn (seller profile)	Dinner in the Dark Event Supplies
Condition: New	

Shipping Speed:
Standard Shipping

Payment information

Payment Method:
Visa | Last digits: 7039

Item(s) Subtotal: \$149.99
Shipping & Handling: \$0.00

Billing address
Brenda Morgan
301 MAIN ST STE 103
LEWISTON, ID 83501-1819
United States

Total before tax: \$149.99
Estimated tax to be collected: \$12.30

Grand Total: \$162.29

Credit Card transactions

Visa ending in 7039: January 4, 2023: \$162.29

To view the status of your order, return to [Order Summary](#).



Final Details for Order #113-5774978-7897803

[Print this page for your records.](#)

Order Placed: January 30, 2023

Amazon.com order number: 113-5774978-7897803

Order Total: \$64.86

Shipped on January 31, 2023

Items Ordered

1 of: 6 Pack Black Round Tablecloths 90 Inch - Circle Bulk Linen Polyester Fabric

Washable Table Clothes Cover for Wedding Reception Banquet Party Buffet Restaurant

Sold by: BRILLMAX ([seller profile](#))

Condition: New

Price

\$59.94

2023 BID Town Hall Meeting Supplies

Shipping Speed:

Standard Shipping

Payment information

Payment Method:

Visa | Last digits: 7039

Item(s) Subtotal: \$59.94

Shipping & Handling: \$0.00

Billing address

Brenda Morgan

301 MAIN ST STE 103

LEWISTON, ID 83501-1819

United States

Total before tax: \$59.94

Estimated tax to be collected: \$4.92

Grand Total: \$64.86

Credit Card transactions

Visa ending in 7039: January 31, 2023: \$64.86

To view the status of your order, return to [Order Summary](#).



Final Details for Order #113-0364233-2936234

[Print this page for your records.](#)

Order Placed: January 25, 2023

Amazon.com order number: 113-0364233-2936234

Order Total: \$64.86

Shipped on January 30, 2023

Items Ordered

1 of: *6 Pack Black Round Tablecloths 90 Inch - Circle Bulk Linen Polyester Fabric Washable Table Clothes Cover for Wedding Reception Banquet Party Buffet Restaurant*
Sold by: BRILLMAX ([seller profile](#))

Price

\$59.94

2023 BID Town Hall Meeting Supplies

Condition: New

Shipping Speed:

Two-Day Shipping

Payment information

Payment Method:

Visa | Last digits: 7039

Item(s) Subtotal: \$59.94

Shipping & Handling: \$0.00

Total before tax: \$59.94

Estimated tax to be collected: \$4.92

Grand Total: \$64.86

Billing address

Brenda Morgan
301 MAIN ST STE 103
LEWISTON, ID 83501-1819
United States

Credit Card transactions

Visa ending in 7039: January 30, 2023: \$64.86

To view the status of your order, return to [Order Summary](#).



Final Details for Order #111-7643316-9545060

[Print this page for your records.](#)

Order Placed: January 10, 2023

Amazon.com order number: 111-7643316-9545060

Order Total: \$107.01

Shipped on January 10, 2023

Items Ordered

Price

1 of: Azar Displays 206325-CLR X-Large Clear Acrylic Suggestion Box with Lock & Keys - Donation Box with Lock and Sign Holder on Pedestal - Locking Box with Slot 11" W x 8.25" D x 8.25" H - Offering Box - \$98.90

Sold by: AZAR ([seller profile](#))

2023 BID Town Hall Meeting Supplies

Condition: New

Shipping Speed:

Two-Day Shipping

Payment information

Payment Method:

Visa | Last digits: 7039

Item(s) Subtotal: \$98.90
Shipping & Handling: \$0.00

Billing address

Brenda Morgan
301 MAIN ST STE 103
LEWISTON, ID 83501-1819
United States

Total before tax: \$98.90
Estimated tax to be collected: \$8.11

Grand Total: \$107.01

Credit Card transactions

Visa ending in 7039: January 10, 2023: \$107.01

To view the status of your order, return to [Order Summary](#).



INVOICE

Neon One, LLC
PO BOX 677136
DALLAS TX 75267-7136
United States

Invoice# INV261198
Invoice Date: 01/16/2023
Due Date: 01/17/2023
Payment Terms: Due on receipt - auto
Invoice Amount: \$153.47

Bill To

CUST07737 Beautiful Downtown Lewiston
301 Main Street, #103
Lewiston ID 83501
United States

Monthly CRM Software Charge

ITEM / BUNDLE	DESCRIPTION	AMOUNT
NeonCRM Impact Subscription Fee	NeonCRM Impact Subscription Fee	153.47
NCRM Workflows	Workflows (15)	0.00
NCRM Support - Live Chat	Live Chat and Phone Support	0.00

Remittance Information

Preferred: Pay by credit card or e-check/ACH
Click this [secure link](#) to submit a one-time payment and optionally save payment information for future billing.

NOTICE: Neon One now has a new remittance address for check payments. Please make sure to review the remittance address below.

Subtotal	\$153.47 US Dollar
Tax	\$0.00 US Dollar
Total	\$153.47 US Dollar
Amount Due	\$153.47 US Dollar
Balance	\$153.47 US Dollar
Overdue Balance	\$0.00 US Dollar

To pay by check, send your payment to:

Neon One, LLC
PO BOX 677136
DALLAS TX 75267-7136

Neon One Customer Billing Portal

[Please Click Here](#) to access your billing portal to view invoices, payment history, and statements.

If this is your first time logging in, please use the "Forgot your password?" option and complete the steps to create a new password. You will receive an email with a link to create your password.

Thank you for being part of the Neon One, LLC community!
Questions about this Invoice? Please contact us at (888) 860-6366 x2 or billing@neonone.com



KATW
 403 Capital Street
 Lewiston, ID 83501
 208-743-6564

KATW Statement of Account

Account ID: 0718
 Statement Date: 1/1/2023
 Account Rep: Danielle Seideman

Please Pay This Amount **\$216.00**

Amount Paid: _____

BEAUTIFUL DOWNTOWN LEWISTON
 301 MAIN STREET SUE 103
 LEWISTON, ID 83501

Dinner in the Dark Ads

Payment Terms 10 Days

Sponsor: Beautiful Downtown Lewiston

Page 1

Reference	Date	Type	Description	Amount	Balance
22110210	11/30/2022	INV	Invoice: KATW 0718-027 Beautiful Downtown Lewiston	324.00	
22120209	12/27/2022	PMT	-Payment Check 3518 on Inv 22110210 Beautiful Downt	-324.00	0.00
22120258	12/31/2022	INV	Invoice: KATW 0718-029 Beautiful Downtown Lewiston	216.00	216.00
Statement Total:					216.00

Please Pay This Amount **216.00**

Current	31-60 Days	61-90 Days	91-120 Days	121+ Days	Total Due
216.00					216.00



McVey Entertainment Group, LLC
 KOZE AM & FM KMOK KVTY KRLC
 2575 Snake River Avenue
 Lewiston ID 83501

Statement of Account

Account ID: 0290
 Statement Date: 1/3/2023
 Account Rep: Jenna Kirk

Please Pay This Amount **\$850.00**

Amount Paid: _____

BEAUTIFUL DOWNTOWN LEWISTON
 301 MAIN STREET, SUITE 103
 LEWISTON, ID 83501

Dinner in the Dark Ads

All of us at McVey Entertainment Group wish
 you and yours a very Happy New Year!

Sponsor: Beautiful Downtown Lewiston

Page 1

Reference	Date	Type	Description	Amount	Balance
BalForward	12/1/2022	Bal	Balance Forward as of 11/30/2022	0.00	0.00
22120166	12/31/2022	INV	Invoice: KVTY 0290-020 BDL Update Pa	150.00	150.00
22120167	12/31/2022	INV	Invoice: KMOK 0290-020 BDL Update P	200.00	350.00
22120168	12/31/2022	INV	Invoice: KRLC 0290-020 BDL Update P	150.00	500.00
22120169	12/31/2022	INV	Invoice: KVTY 0290-021 BDL Update ad	100.00	600.00
22120170	12/31/2022	INV	Invoice: KMOK 0290-021 BDL Update a	150.00	750.00
22120171	12/31/2022	INV	Invoice: KRLC 0290-021 BDL Update ad	100.00	850.00
Statement Total:					\$850.00

Please Pay This Amount **\$850.00**

Current	31-60 Days	61-90 Days	91-120 Days	121+ Days	Total Due
\$850.00					\$850.00



Beautiful Downtown Lewiston

Facilitated Discussion

Memorandum of Understanding

This is Memorandum of Understanding (MOU) between Beautiful Downtown Lewiston (client), and Kari Anderson (contractor) for facilitation services to be provided for Beautiful Downtown Lewiston on May 9, 2023.

Scope of Services - contractor

Contractor agrees to deliver the following for Beautiful Downtown Lewiston:

- Meet via phone or Zoom with Beautiful Downtown Lewiston leadership to assess organization, assemble data points and determine areas of attention for quarterly meeting with community stakeholders
- Facilitate quarterly meeting of client stakeholders on May 9, 2023
- Provide executive summary of discussion, including key takeaways and action items

Scope of Services - client

Beautiful Downtown Lewiston agrees to provide the following in conjunction with the quarterly meeting:

- Ensure attendance of Beautiful Downtown Lewiston stakeholders (board, association members, sponsors)
- Provide attendee contact information for post-session follow up purposes

Compensation:

- Contractor's fee for service is \$1,000, fee due on or before time of service
- Contractor requests reimbursement for travel fees, including hotel and mileage reimbursement, not to exceed \$500

Independent Contractor:

- 3.11.14
- Contractor acknowledges that services rendered under this MOU shall be performed by him or her as an independent contractor. Contractor is responsible for the payment of all federal, state and local income taxes related to his fees for service.

Remedies:

- Should tasks listed under Section II: Scope of Services not be carried out by the Contractor as agreed upon, all compensation will be refunded to Beautiful Downtown Lewiston. In addition to any and all other rights a party may have available according to law, if a party defaults by failing to substantially perform any provision, term, or condition of this MOU, the other party may terminate the MOU by providing written notice to the defaulting party. Unless waived by a party providing notice, the failure to cure the defaults within such time period shall result in the automatic termination of this contract.

Confidentiality:

- Both parties agree to adhere to generally accepted confidentiality practices and to provide each other with their best efforts in fulfillment of this contract. Contractor agrees not to disclose private information about the organization or its donors. "Private information" does not include information available in the public domain.

Guarantees:

- Contractor shall perform all duties requested and agreed to by both parties and shall submit work in good faith. This contract may be renegotiated or terminated with 15 days written notice at the request of either party.

Entire MOU:

- This MOU contains the entire MOU of the parties, and there are no other promises or condition in any other MOU concerning the subject matter. This MOU may be amended or modified in writing.

By and Between:

Contractor:

Kari Anderson, Principal, Incite! Consulting Group

Date:

Client: Beautiful Downtown Lewiston

Printed Name & Title: Brenda Morgan, Executive Director

Date:

Signature:

soofa sign

The neighborhood news feed for smart cities.



A 100% solar-powered, turnkey solution for city communication and wayfinding.



On-demand pedestrian data.



Install in minutes with no wires. 100% Sustainable.



Increase access to vital community information.

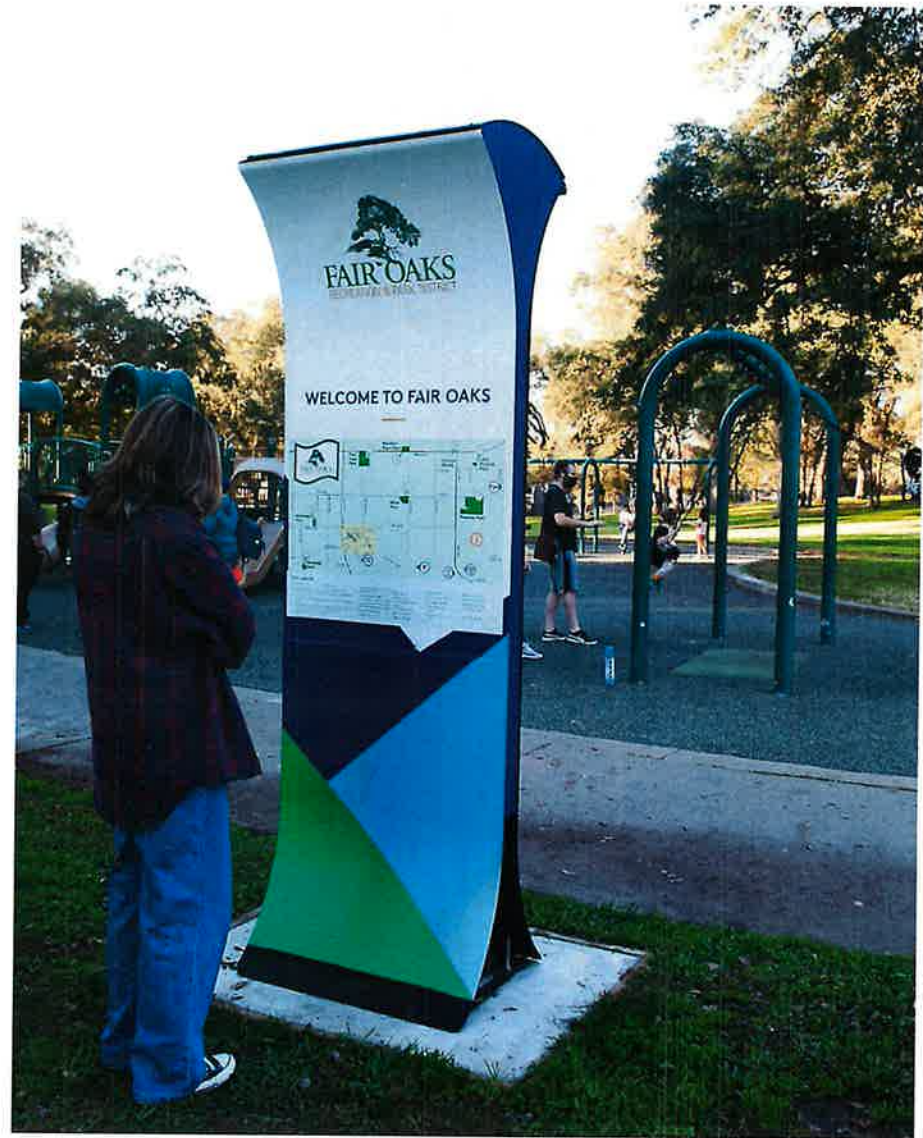

soofa

M.I.D.

Make vital community information accessible to all.

Communicate news and PSAs to all, including those without access to the internet or devices.

Soofa Signs are a trusted source of information on health guidelines, events, public works, and more.



Build a display customized to your municipality's needs.

Digital display options include:

- Real-time transit schedule
- Events
- Opinion polls
- Emergency Alerts
- Social Media Feeds

Automatically share social posts, transit updates, and emergency alerts in real time. Localize messaging and reach specific neighborhoods with our online platform.



Widgets customized for every city

Share vital community information in the Local Updates widget to ensure residents and visitors in your area hear from you.

There is no limit to the amount of posts, our system will just rotate through depending on the amount.



Events



Local Updates



Transit



Restaurants



Tweets



Poll / Opinion



News

The screenshot displays the Springfield Neighborhood app interface. At the top, it says "SPRINGFIELD NEIGHBORHOOD" and "Jan 24th" with a weather forecast of "Partly Cloudy" and temperatures of "↑ 72°" and "↓ 52°". The "Local Updates" widget is highlighted with a teal border and shows a "SUMMER SCREEN ON THE GREEN" event. Below it are three movie listings: "Encanto" (06.17), "Turning Red" (07.08), and "Cruella" (07.22). The "Transit" widget shows bus routes: "102 University Drive" (10:01-10:21), "E-Line New Hope Commons" (10:24-11:24), and "24 LTD to 87 Ave" (10:34). The "Local News" widget features a "Neighborhood Workshop 2021" announcement for Feb 01, 2022, and a "Springfield Begins Multi-Mile Road Project" announcement for Sep 20, 2022. A "Poll / Opinion" widget shows a question: "Going to relax on a beach somewhere. Not sure where yet, but the ocean is calling my name." with a post date of "Sat Mar 3".

Widgets customized for every city

Soofa signs can integrate with a transit API or GTFS feed to display real-time transit for pedestrians.

The transit applet updates every two minutes, and displays the line, location, and next scheduled arrival.

- Events
- Local Updates
- Transit
- Restaurants
- Tweets
- Poll / Opinion
- News

The screenshot shows a Soofa sign for Springfield Neighborhood. At the top right, it displays the date "Jan 24th" and weather information: "Partly Cloudy" with a high of 72° and a low of 52°. The main content is a "Transit" widget with three entries:

- 102** University Drive: 10:01 - 10:21 (BUS)
- E-Line** New Hope Commons: 10:24 - 11:24 (RAIL)
- 24** LTD to 87 Ave: 10:34 (BUS)

Below the transit widget is a "Local News" section with a "+18 More" link and a QR code. The news items include:

- Neighborhood Workshop 2021** (Fri, 01 Feb 2022): To further promote neighborhood engagement, the City of Springfield is hosting a Neighborhood Workshop on Tuesday, Oct...
- Springfield Begins Multi-Mile Road Project** (Mon, 20 Sep 2022): Contractors will begin work on a multi-mile roadway improvement project in Springfield starting Tuesday, Sept. 21 with milling and...
- Springfield Passes Ordinance for Golf Carts**

At the bottom, there are three tweet snippets:

- "Going to a concert! Posted at 10:45am"
- "Cincinnati baby! Posted at 2:24pm"
- "Going to relax on a beach somewhere. Not sure where yet, but the ocean is calling my name. Posted at 11:42am, Sat Mar 3"



Generate community revenue with advertising

With our digital and static advertising models, you'll get a 20% net revenue share of every ad that runs on your sign.

Digital ads display for minutes within the hour while still keeping your community feed on the screen for all to see.

Ads take 80% of screen space

Your preferred widget stays at the bottom

BOSTON BALLET
MUSIC BY MARIUS STAPANSKY

CARMEN

bostonballet.org **OPERA HOUSE**

Local Events +22 More

Boston Market
Event Time: 12:00 AM - 11:59 PM Location: Downtown
Come to the Boston Market weekly to shop for fresh local produce, handmade products, and beautiful plants and flowers. The fresh produce will live up even your favorite recipes or grab lunch on the go from one of the wonderful food vendors...

Board of Works Meeting
Event Time: 10:00 AM - 11:00 AM Location: 166 Lincolnway, Boston

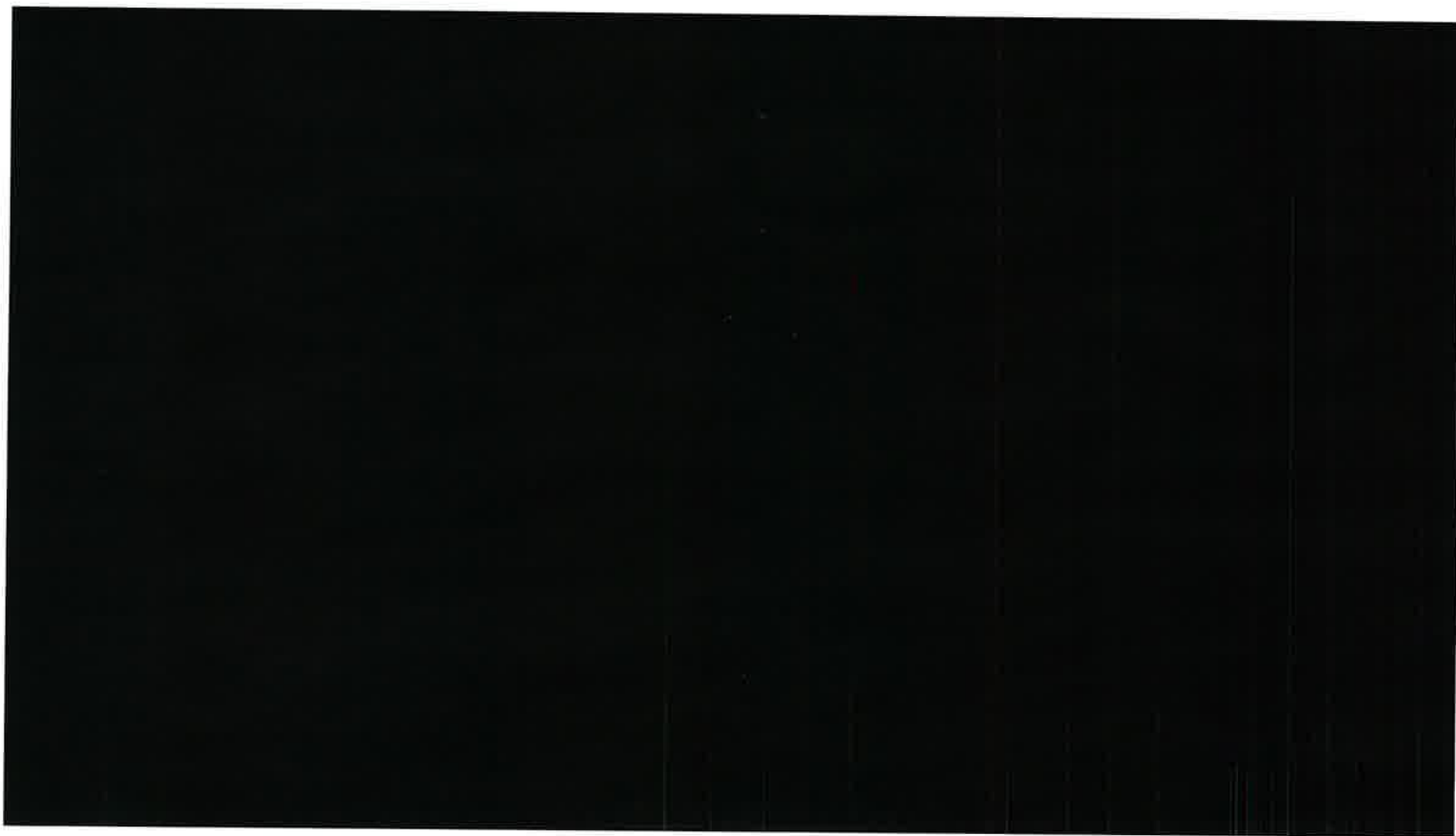

Timely and relevant updates in just a few clicks.

Our platform, SoofaTalk, allows cities to post to Signs instantly across different neighborhoods.



Gain on-demand access to hyperlocal pedestrian data and insights.

Access data from our pedestrian sensor online.

Use the data to better understand use of your public spaces, automate people counting, and support local initiatives and economic planning.





Full transparency into the performance of your Signs.

You can view Operating Hours, a live view of the Sign, and minute by minute engagement on SoofaTalk. Soofa creates a transparent product so municipalities can clearly see how the product is working.

soofa talk

Bennington St 1

Live view

Operating Hours: 7:00am - 6:00am

Last Maint. Check: 04/06/2021

Status: 



This Sign is currently awake.

Explore Heartbeat Analytics



REVERE APRIL 15TH, 2021
NEIGHBORHOOD NEWS FEED 61°

Opinion

What alternate universe would you live in?

Submit your answer on SoofaBuzz.com

one to which we respected the lives of all animals

A grape favored one

Local Updates



Promoted Posts

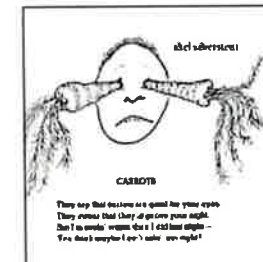

Transit



soofa

Enhance wayfinding and welcome visitors with custom vinyl decals.

Help pedestrians navigate the area and drive traffic to local attractions and businesses with an eye-catching vinyl sticker reflecting the character of the neighborhood.



Give local businesses the stage with static vinyl advertising

With Soofa's advertising models, local and national businesses can add personality and relevant content to your signs while you collect 20% of the net ad revenue.



Standard Operating Agreement

Soofa partnerships include:

- 20% share of net revenue annually
- Dedicated space for city messaging
- Custom vinyl decal
- Access to on-demand pedestrian data
- Real-time transit updates

Partnerships include Soofa's white-glove service:

- Sign cleaning and maintenance
- Installation
- Content management





Soofa Models & Pricing



Community-Branded



Digital Advertising Allowed
Static Advertising not Allowed



Digital & Static
Advertising Allowed

Interactive City Communication	✓	✓	✓
Interactive Widgets	✓	✓	✓
City Branded Wrap	✓	✓	•
Advertiser Branded Wrap	•	•	✓
Interactive Advertising	•	✓	✓
Revenue Share	•	20%	20%
One Time Cost to City	\$25,000	\$18,000	\$16,000
Annual Fee After Year 1	\$6,200	\$6,200	\$2,000

Advertising and Revenue Share

Once your Soofa Sign is installed, it can take up to one year to start securing advertisers. To account for this, **annual fees do not kick in until year two.**

If there are prominent companies or brands within your community that would be interested in advertising on your Soofa Signs, please facilitate an introduction and **we'll do the rest!**



soofa

Next Steps

Stakeholder Approvals

- Develop a shared understanding of procurement and city-side approvals
- Present to additional departments

Discuss Installation Details

- Determine potential locations via site survey

Education on Soofa Talk

- Demo of SoofaTalk, our online platform



Thank you!

www.soofadigital.com/soofa-sign

soofa®

Appendix





Choose which features you want to display on the Sign.



Events calendar
Weather updates

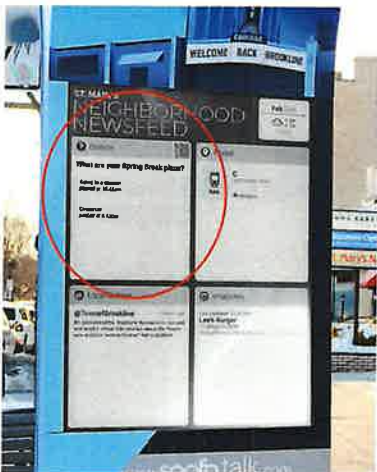

Polling widget



Real-time transit
information

Performance

- Upto 23 hours operating hours/day
- Sensor-enabled LED overhead light illuminates screen in the dark
- Soofa Operations Team monitors performance metrics remotely

Durability

- Proven seamless operation in extreme temperatures -10 to 100F (From Vegas to Boston)
- Epoxy powder-coating protects from graffiti, rust and corrosion

Specs

Solar powered

- Solar panel: 65W
- Battery: 24V, 12Ah
- Wireless connectivity

Electronic paper display

- Sixteen shades of grey
- 42" screen size
- High resolution imaging

Beautiful, sturdy design

- Structure: steel
- Finish: zinc & polyester powder coated

Simple, four bolt installation

- Suggested anchors
 - 8" 1/2 dia. threaded rods
 - 1/2" theft proof nuts

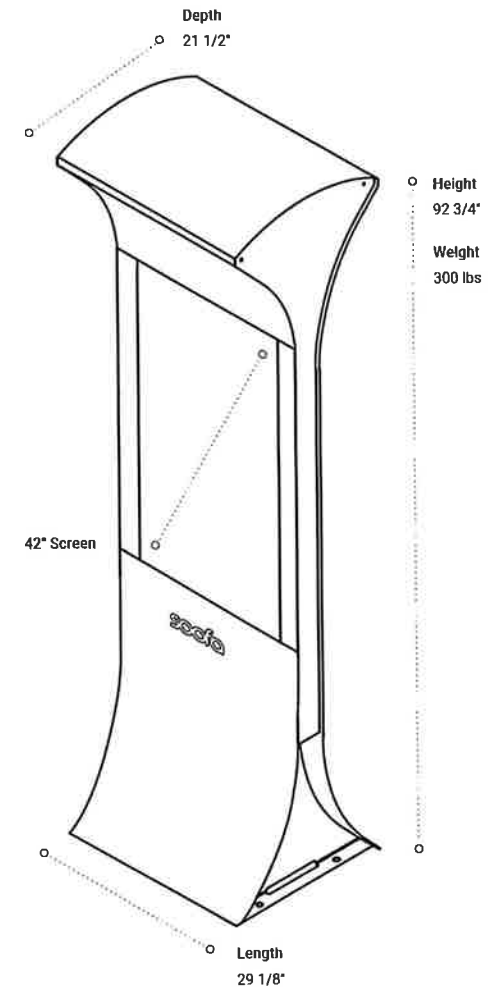

Plug-and-play Installation

- 20min installation with four bolts (no wiring)
- Apps are setup in advance and content is preloaded
- Small footprint for easy placement: 21.5" x 29.1"
- Engineered to withstand hurricane force winds (180mph)

