

**City of Simi Valley
Staff Report**

April 20, 2026

To: City Council

From: Public Works Department
Ron Fuchiwaki, Public Works Director

Subject: Approve the purchase of one replacement vehicle for the Sanitation Division utilizing the Sourcwell Cooperative Agreement No. 110421-EEC

Staff Recommendation

It is recommended that the City Council approve issuance of a purchase order to Nixon-Egli Equipment Company (Nixon-Egli), for a Sanitation Division replacement vehicle utilizing the Sourcwell Cooperative Agreement, No. 110421-EEC, with Elliott Equipment Company for one (1) Crane Truck in the amount of \$435,165.35.

Background

On June 9, 2025, the City Council approved the FY 2025-26 budget, which allocated \$2,452,000 for the replacement of Public Works vehicles. Due to age, high maintenance costs, limited availability of replacement parts, and the California Air Resources Board (CARB) requirements that necessitate newer model year engines, one vehicle in the Public Works Sanitation fleet—Vehicle No. 478 (Crane Truck)—was approved for replacement. Staff obtained a quote through the Sourcwell Cooperative Agreement and recommends City Council approval of a purchase order for the replacement vehicle.

Discussion

Sourcwell is a cooperative purchasing program available to government agencies, providing competitively bid contracts that streamline procurement and reduce staff time. The City's Purchasing Ordinance, Section 2-9.201(f), authorizes the use of cooperative purchasing methods such as Sourcwell, recognizing the efficiency and competitive pricing they offer. Based on its review, staff determined that Nixon-Egli, an authorized dealer of Elliott Equipment Company, best meets the City's required specifications.

Sanitation Vehicle No. 478, a 2004 Freightliner M2 Crane Truck, will be replaced with a 2027 International HV607 Elliot 1870F Crane Truck. The existing crane truck is no longer CARB compliant, requires frequent repairs, and is routinely out of service. This equipment is used at the Water Quality Control Plant to extract and install various submersible and vertical turbine pumps, equipment, and materials in remote and challenging areas such as vaults and elevated areas. It also serves as a source of power for start-ups, power tools, and provides welding capabilities for in-field repairs.

On April 7, 2026, Nixon-Egli provided a quote in the amount of \$435,165.35 for the Crane Truck (Attachment A). Sourcwell Contract No. 110421-EEC with Elliot Equipment

Company (Elliot) (Attachment B) is valid through December 27, 2026. Elliot does not sell directly to municipalities; purchases are made through the local distributor, Nixon-Egli, located in Ontario, CA, and serving as Ventura County's contracted Elliot dealer under this agreement. Funding in the amount of \$637,425 is available in the FY 2025-26 Sanitation vehicle replacement budget to complete the purchase.

Financial Impact

\$435,165.35. The cost of this action was included in the FY 2025-26 Adopted Budget to the Public Works Vehicle Replacements. No additional appropriation is required.

City Council Priority

This item supports the Reliable Infrastructure Pillar of Excellence.

Suggested Motion

I move to approve issuance of a purchase order for a Sanitation Division replacement vehicle utilizing the Sourcewell Cooperative Agreement, No. 110421-EEC, with Nixon-Egli for one (1) Crane Truck in the amount of \$435,165.35.

Summary

On June 9, 2025, the City Council approved the FY 2025-26 budget, which allocated \$2,452,000 for the replacement of Public Works vehicles, with \$637,425 currently available in that fund. Due to age, high maintenance costs, limited availability of replacement parts, and the California Air Resources Board (CARB) requirements that necessitate newer model year engines, one vehicle in the Public Works Sanitation fleet—Vehicle No. 478 (Crane Truck)—was approved for replacement. Staff recommends that the City Council approve one (1) purchase order for a Public Works replacement vehicle utilizing the Sourcewell Cooperative Agreement, No. 110421-EEC with Nixon-Egli for one (1) Crane Truck in the amount of \$435,165.35.

Prepared by: Matt Mckenna, Senior Management Analyst

Attachments:

Attachment A – Nixon-Egli Quote

Attachment B – Sourcewell Cooperative Agreement No. 110421-EEC

- SO. CALIFORNIA: 2044 South Vineyard Avenue, Ontario, CA 91761 • (909) 930-1822 • FAX (909) 923-2356
 □ NO. CALIFORNIA: 800 East Grant Line Road, Tracy, CA 95376 • (209) 830-8600 • FAX (209) 830-8884

City of Simi Valley

600 W Los Angeles Ave
 Simi Valley, CA 93065

April 7, 2026

Nixon Quote# 101535 R3

Reference: Elliott 1870F Boom Truck

Elliott Sourcewell Contract # 110421-EEC

Attention: Jason Denison / Travis Fisher



We are pleased to provide you with a quotation on a new **Elliott 1870F** equipped as follows:

Standard Equipment:

- Capacity- 18 tons at 5-foot radius
- Front Mount Turret with Boom Stowed Over the Rear of the Truck
- Unit certified to ASME B30.5 for Mobile Cranes
- Boom- 3-section, 4-plate design
- Two-Block- Internal hard-wired
- Load Moment Indicator (LMI) protection system
- Sheave Head- 3 Sheaves
- Boom Extension- Hydraulic with Cables (Proportional Boom)
- 372-degree non-continuous rotation
- Winch- 12,800 lb. bare drum pull with 275' of 9/16" diameter 6x37 EIPS wire rope (9,600 lb. single line pull) Includes burst of speed.
- Downhaul Ball and Hook
- Oil Reservoir- Steel, 70 gallon capacity includes Sight and Temperature Gauge
- Subframe-High Strength Full Length
- Removable Boom Rest at End of Subframe
- Lower Controls- Dual operator control console and platforms with engine start/stop switch, independently controlled outrigger and stabilizer levers, bubble level gauge, signal horn, variable speed foot throttle, lifting capacity chart, range diagram chart, boom angle indicator, system pressure gauge (roadside), cup holder, and 12V power outlet.
- Front Outriggers- "A" frame link type outriggers at crane pedestal with 20'-10" spread
- Rear Stabilizers-"A" frame type rear stabilizers behind rear axle with 10'-4" spread
- Outrigger Controls- Hydraulic located at lower control station
- 180-degree stability without front bumper stabilizer
- Hydraulic Pump- 3-section gear pump (CCW rotation)
- Manuals- (1) Operation, Maintenance and Safety, (1) Parts and (2) Electronic copies of each
- Maintenance Filters (Additional)- (1) high-pressure and (1) return filter

- SO. CALIFORNIA: 2044 South Vineyard Avenue, Ontario, CA 91761 • (909) 930-1822 • FAX (909) 923-2356
- NO. CALIFORNIA: 800 East Grant Line Road, Tracy, CA 95376 • (209) 830-8600 • FAX (209) 830-8884

Included Options:

- Base 1870F (80-foot tip height) (27'-0" retracted / 70'-0" extended)

Bed Options:

- 20' Wood Bed with LED Lights (1,800 lbs.)

Outrigger / Stabilizer Options:

- Front Bumper Stabilizer for 360-Degree Area of Operation. (Includes Additional Control Valve)
- Mounting Charge for Front Bumper Stabilizer. (For Ext Front Frame Rails Only)

Lifting Options:

- 275' of 9/16" Diameter Spin Resistant Wire Rope, In Lieu of Standard Wire Rope.
- 15-Ton Single Sheave Hook Block For 2/3 Parts of Line. (240 lbs.)

Remote Control Options:

- 4-Function Radio Remote Controls

PTO Options:

- Hot Shift PTO For Automatic Transmission
- Clockwise Rotation Pump (Required for Automatic Transmission)

Toolbox Options (Aluminum):

- (4) 24" x 24" x 24" Aluminum Underbody Mounted (Treadplate-No paint) **Front Both Sided & Rear Both Sides**
- 48" x 24" x 24" Aluminum Underbody Mounted (Treadplate-No paint) **Passenger Side**

Additional Options:

- Fold Down Bed Access Ladder With Grab Handles
- Vertical Holder On Bed For 2/3 Part Line Hook Block
- (2) LED Work Lights Mounted on Side of Boom With Switch in Cab.
- (2) Whelen TLIA ION T-Series Strobes mounted in front grille, (2) Whelen TLIA ION T-Series Strobes mounted in rear bumper area. Controlled by one switch in the cab.
- Camera- Rear View (Elliott 3021942)

Custom Options:

- Miller Trailblazer 330 Diesel Welder **with optional battery charge / crank assist feature**. Includes wireless interface control. Welder mounted in center of bed towards front of bed.
- Driver Side toolboxes to include 7" drawer sets
- Passenger Side toolboxes to include 4" drawer sets with dividers

NIXON-EGLI EQUIPMENT CO.

www.nixon-egli.com

- SO. CALIFORNIA: 2044 South Vineyard Avenue, Ontario, CA 91761 • (909) 930-1822 • FAX (909) 923-2356
 □ NO. CALIFORNIA: 800 East Grant Line Road, Tracy, CA 95376 • (209) 830-8600 • FAX (209) 830-8884

Chassis:

2027 International HV607 {Cummins L9} 300HP Allison 3000 RDS_P Speed Automatic
 Transmission 56,000 GVWR, 16k Front Axle, 40k Rear Axles

Unit List Price:	\$271,750.00
Sourewell Discount 10%	-\$27,175.00
Unit Price:	\$244,575.00
Chassis:	\$128,945.19
Dealer Items:	\$32,228.39
Subtotal:	\$405,748.58
Sales Tax (Ventura County 7.25%):	\$29,416.77
Total Price:	\$435,165.35

Freight will be via driveaway service.

Lead Time – 400 Days ARO (Subject to Change)

Thank you for the opportunity to quote on your equipment needs. If you have any further questions, please feel free to contact me.

Sincerely,
NIXON-EGLI EQUIPMENT CO.
 Christian Velasco
 Municipal Area Manager



HV607 SBA

Sales Proposal For:

Nixon-Egli Equipment Company

Presented By:

WESTRUX INT'L., INC.

Prepared For:

Nixon-Egli Equipment Company
 Christian Velasco
 2044 S Vineyard Ave.
 Ontario, CA 91761-7748
 (909)930 - 1822
 Reference ID: N/A

Presented By:

WESTRUX INT'L., INC.
 Lucas Berry
 15555 Valley View Ave.
 Santa Fe Springs CA 90670 -
 (562)404-1020

Thank you for the opportunity to provide you with the following quotation on a new International truck. I am sure the following detailed specification will meet your operational requirements, and I look forward to serving your business needs.

Model Profile
2027 HV607 SBA (HV607)

AXLE CONFIG: 4X2
APPLICATION: Mobile Aerial Crane
MISSION: Requested GVWR: 33000. Calc. GVWR: 33000. Calc. GCWR: 60000
 Calc. Start / Grade Ability: 44.55% / 4.53% @ 55 MPH
 Calc. Geared Speed: 63.5 MPH
DIMENSION: Wheelbase: 169.00, CA: 101.90, Axle to Frame: 120.00
ENGINE, DIESEL: {Cummins L9 350} EPA 2024, 350HP @ 2200 RPM, 1050 lb-ft Torque @ 1200 RPM, 2200 RPM
 Governed Speed, 350 Peak HP (Max)
TRANSMISSION, AUTOMATIC: {Allison 3000 RDS} 6th Generation Controls, Close Ratio, 6-Speed with Double Overdrive, with
 PTO Provision, Less Retarder, Includes Oil Level Sensor, with 80,000-lb GVW and GCW Max,
 On/Off Highway
CLUTCH: Omit Item (Clutch & Control)
AXLE, FRONT NON-DRIVING: {Dana Spicer E-1202W} Wide Track, I-Beam Type, 12,000-lb Capacity
AXLE, REAR, SINGLE: {Dana Spicer 21060D} Single Reduction, 21,000-lb Capacity, Driver Control Locking Differential,
 R Wheel Ends Gear Ratio: 6.50
CAB: Conventional, Day Cab
TIRE, FRONT: (2) 11R22.5 Load Range H HDC 3 (CONTINENTAL), 492 rev/mile, 68 MPH, Drive
TIRE, REAR: (4) 11R22.5 Load Range H HDC 3 (CONTINENTAL), 492 rev/mile, 68 MPH, Drive
SUSPENSION, REAR, AIR, SINGLE: {Hendrickson HAS 230} 23,000-lb Capacity, 9.5" Ride Height, with Shock Absorbers
PAINT: Cab schematic 100WL
 Location 1: 9219, Winter White (Std)
 Chassis schematic N/A

8
Vehicle Specifications
2027 HV607 SBA (HV607)

<u>Code</u>	<u>Description</u>	<u>F/R Wt</u> (lbs)	<u>Tot Wt</u> (lbs)
HV60700	Base Chassis, Model HV607 SBA with 169.00 Wheelbase, 101.90 CA, and 120.00 Axle to Frame.	6136/3544	9680

AXLE CONFIGURATION

1ANA	AXLE CONFIGURATION 4x2	0/0	0
------	------------------------	-----	---

Notes
: Pricing may change if axle configuration is changed.

ENGINE

12EYY	ENGINE, DIESEL {Cummins L9 350} EPA 2024, 350HP @ 2200 RPM, 1050 lb-ft Torque @ 1200 RPM, 2200 RPM Governed Speed, 350 Peak HP (Max)	555/9	564
12VKL	EMISSION, CALENDAR YEAR {Cummins L9} EPA, OBD and GHG Certified for Calendar Year 2026	0/0	0
12WZY	CARB EMISSION WARR COMPLIANCE for Cummins L9 Engines	0/0	0
12WZJ	CARB IDLE COMPLIANCE Low NOx Idle Engine, Complies with California Clean Air Regulations; Includes "Certified Clean Idle" Decal located on Driver Door	0/0	0
12WVH	EPA IDLE COMPLIANCE Low NOx Idle Engine, Complies with EPA Clean Air Regulations; Includes "Certified Clean Idle" Decal on Door	0/0	0
10UAZ	VEHICLE REGISTRATION IDENTITY ID for the State of California Less Surcharge	0/0	0
12UWY	RADIATOR Aluminum, Cross Flow, Front to Back System, 1228 SqIn, with 1167 SqIn Charge Air Cooler	0/0	0
	<u>Includes</u> : DEAERATION SYSTEM with Surge Tank : HOSE CLAMPS, RADIATOR HOSES Gates Shrink Band Type; Thermoplastic Coolant Hose Clamps : RADIATOR HOSES Premium, Rubber		
12THT	FAN DRIVE {Horton Drivemaster} Two-Speed Type, Direct Drive, with Residual Torque Device for Disengaged Fan Speed	0/0	0
	<u>Includes</u> : FAN Nylon		
12VBC	AIR CLEANER Single Element	0/0	0
12703	ANTI-FREEZE Red, Extended Life Coolant; To -40 Degrees F/ -40 Degrees C, Freeze Protection	0/0	0
12849	BLOCK HEATER, ENGINE 120V/1000W, for Cummins ISB/B6.7/ISL/L9 Engines	3/0	3
	<u>Includes</u> : BLOCK HEATER SOCKET Receptacle Type; Mounted below Drivers Door		
12XBM	ENGINE CONTROL, REMOTE MOUNTED Provision for; Includes Wiring for Body Builder Installation of PTO Controls and Starter Lockout, with Ignition Switch Control, for Cummins B6.7 and L9 Engines	0/0	0
12VXU	THROTTLE, HAND CONTROL Engine Speed Control for PTO; Electronic, Stationary Pre-Set, Two Speed Settings; Mounted on Steering Wheel	0/0	0

TRANSMISSION

Vehicle Specifications
2027 HV607 SBA (HV607)

February 27, 2026

Code	Description	F/R Wt (lbs)	Tot Wt (lbs)
13BCS	TRANSMISSION, AUTOMATIC {Allison 3000 RDS} 6th Generation Controls, Close Ratio, 6-Speed with Double Overdrive, with PTO Provision, Less Retarder, Includes Oil Level Sensor, with 80,000-lb GVW and GCW Max, On/Off Highway	216/67	283
13WUC	ALLISON SPARE INPUT/OUTPUT for Rugged Duty Series (RDS) and Regional Haul Series (RHS), General Purpose Trucks, Construction, Package Number 223	0/0	0
13WVV	NEUTRAL AT STOP Allison Transmission Shifts to Neutral When Service Brake is Depressed and Vehicle is at Stop; Remains in Neutral Until Service Brake is Released	0/0	0
13WAW	OIL COOLER, TRANSMISSION {Modine} Water to Oil Type	25/0	25
13XAA	PTO CONTROL, DASH MOUNTED For Customer Provided PTO; Includes Switch, Electric/Air Solenoid, Piping and Wiring	3/0	3
13XAM	PTO LOCATION Dual, Customer Intends to Install PTO at Left and/or Right Side of Transmission	0/0	0
13WYU	SHIFT CONTROL PARAMETERS {Allison} 3000 or 4000 Series Transmissions, Performance Programming	0/0	0
13WLP	TRANSMISSION OIL Synthetic; 29 thru 42 Pints	0/0	0
13WET	TRANSMISSION SHIFT CONTROL Column Mounted Stalk Shifter, Not for Use with Allison 1000 & 2000 Series Transmission	1/0	1

CLUTCH

11001	CLUTCH Omit Item (Clutch & Control)	0/0	0
-------	-------------------------------------	-----	---

REAR AXLES, SUSPENSIONS

14AKW	AXLE, REAR, SINGLE {Dana Spicer 21060D} Single Reduction, 21,000-lb Capacity, Driver Control Locking Differential, R Wheel Ends . Gear Ratio: 6.50	0/61	61
14TAX	SUSPENSION, REAR, AIR, SINGLE {Hendrickson HAS 230} 23,000-lb Capacity, 9.5" Ride Height, with Shock Absorbers	0/95	95
14899	SUSPENSION AIR CONTROL VALVE Pressure Release Control In Cab	0/1	1

FRONT AXLES

2AGE	AXLE, FRONT NON-DRIVING {Dana Spicer E-1202W} Wide Track, I-Beam Type, 12,000-lb Capacity	-9/0	-9
------	---	------	----

FRONT SUSPENSIONS

3ADC	SUSPENSION, FRONT, SPRING Parabolic Taper Leaf, Shackle Type, 12,000-lb Capacity, with Shock Absorbers	0/0	0
------	--	-----	---

CABS, COWLS, BODIES

16030	CAB Conventional, Day Cab	0/0	0
16ZBT	ACCESS, CAB Steel, Driver & Passenger Sides, Two Steps per Door, for use with Day Cab and Extended Cab	0/0	0
16BAM	AIR CONDITIONER with Integral Heater and Defroster	0/0	0
16VKB	CAB INTERIOR TRIM Classic, for Day Cab	0/0	0

Vehicle Specifications
2027 HV607 SBA (HV607)

<u>Code</u>	<u>Description</u>	<u>F/R Wt</u> (lbs)	<u>Tot Wt</u> (lbs)
	<u>Includes</u> : CONSOLE, OVERHEAD Molded Plastic with Dual Storage Pockets, Retainer Nets and CB Radio Pocket; Located Above Driver and Passenger : DOME LIGHT, CAB Door Activated and Push On-Off at Light Lens, Timed Theater Dimming, Integral to Overhead Console, Center Mounted : SUN VISOR (2) Padded Vinyl; 2 Moveable (Front-to-Side) Primary Visors, Driver Side with Toll Ticket Strap		
16WSK	CAB REAR SUSPENSION Air Bag Type	0/0	0
16WEE	CAB SOUND INSULATION Includes Dash Insulator and Engine Cover Insulator	12/0	12
16GEG	GAUGE CLUSTER Premium Level; English with English Electronic Speedometer	0/0	0
	<u>Includes</u> : GAUGE CLUSTER DISPLAY: Base Level (3" Monochromatic Display), Premium Level (5" LCD Color Display); Odometer, Voltmeter, Diagnostic Messages, Gear Indicator, Trip Odometer, Total Engine Hours, Trip Hours, MPG, Distance to Empty/ Refill for : GAUGE CLUSTER Speedometer, Tachometer, Engine Coolant Temp, Fuel Gauge, DEF Gauge, Oil Pressure Gauge, Primary and Secondary Air Pressure : WARNING SYSTEM Low Fuel, Low DEF, Low Oil Pressure, High Engine Coolant Temp, Low Battery Voltage (Visual and Audible), Low Air Pressure (Primary and Secondary)		
16HLX	GAUGE, VOLTMETER Auxiliary Gauge, Located in Center Panel. Standard Cluster Also Includes Digital Voltage Readout	0/0	0
16XJP	INSTRUMENT PANEL Wing Panel	0/0	0
16HKT	IP CLUSTER DISPLAY On Board Diagnostics Display of Fault Codes in Gauge Cluster	0/0	0
16SNS	MIRRORS (2) Aero Pedestal, Power Adjust, Heated, Black Heads and Arms, 6.5" x 14" Flat Glass, Includes 6.5" x 6" Convex Mirrors, for 102" Load Width	0/0	0
	<u>Notes</u> : Mirror Dimensions are Rounded to the Nearest 0.5"		
16SJW	MIRROR, CONVEX, HOOD MOUNTED {Lang Mekra} (2) Right and Left Sides, Black, Heated, 7.5" Sq.	9/0	9
16VLV	MONITOR, TIRE PRESSURE Omit	-10/-1	-11
16KBE	SEAT, DRIVER {National Model HP} Air Suspension, High Back, Mordura Cloth, 2 Arm Rests, Isolator, 8" Adjuster, 3 Chamber Lumbar, 6 Position Front Cushion Adjust, 3 Position Rear Cushion Adjust, 6-23 Degree Back Angle Adjust, Bellows	0/0	0
16KCR	SEAT, PASSENGER {National Model HP} Air Suspension, High Back, Mordura Cloth, 2 Arm Rests, Isolator, 8" Adjuster, 1 Chamber Lumbar, 2 Position Front Cushion Adjust, 3 Position Rear Cushion Adjust, 6-23 Degree Back Angle Adjust, Bellows	57/27	84
16HCH	SEATBELT WARNING LIGHT IND. Mounted in Dash, Will Flash when Park Brake is Disengaged and Driver Seatbelt Unfastened, Audible Alarm to Remind Driver to Fasten Seatbelt	0/0	0
16XWD	SUNSHADE, EXTERIOR Aerodynamic, Painted Roof Color, with Integral Clearance/Marker Lights	14/3	17
16XCU	TELEMATICS BRACKET with Universal Mount, 1" Ball Mount Size, for Customer Supplied Telematics Device, Mounted to Side Wing Panel	0/0	0

11
Vehicle Specifications
2027 HV607 SBA (HV607)

<u>Code</u>	<u>Description</u>	<u>F/R Wt</u> (lbs)	<u>Tot Wt</u> (lbs)
16WJU	WINDOW, POWER (2) and Power Door Locks, Left and Right Doors, Includes Express Down Feature	0/0	0

FRAMES

1CGE	FRAME RAILS Heat Treated Alloy Steel (125,000 PSI Yield); 11.25" x 4.00" x 0.500" (285.75mm x 101.6mm x 12.7mm); 480.8" (1221.2mm) Maximum OAL	62/966	1028
1LNR	BUMPER, FRONT Swept Back, Steel, Painted 0001 Canyon Black, Heavy Duty	0/0	0
1SAL	CROSSMEMBER, REAR, AF (1)	-6/26	20
1MEJ	FRAME DIMPLE Dimple on Left and Right Top Flange of Frame Rail to Reference Rear Axle Centerline	0/0	0
1UAM	FRAME EXTENSION, FRONT Integral; 27" In Front of Grille	106/-16	90
1570	TOW HOOK, FRONT (2) Frame Mounted	8/0	8
1LEH	LICENSE PLATE HOLDER Single Plate, Swing Type, Mounted Below Front Bumper	3/0	3
1WGR	WHEELBASE RANGE 138" (350cm) Through and Including 187" (475cm)	191/-191	0

BRAKES

4091	BRAKE SYSTEM, AIR Dual System for Straight Truck Applications <u>Includes</u> : BRAKE LINES Color and Size Coded Nylon : DRAIN VALVE Twist-Type : GAUGE, AIR PRESSURE (2) Air 1 and Air 2 Gauges; Located in Instrument Cluster : PARKING BRAKE CONTROL Yellow Knob, Located on Instrument Panel : PARKING BRAKE VALVE For Truck : QUICK RELEASE VALVE On Rear Axle for Spring Brake Release: 1 for 4x2, 2 for 6x4 : SPRING BRAKE MODULATOR VALVE R-7 for 4x2, SR-7 with relay valve for 6x4/8x6	0/0	0
4AZA	AIR BRAKE ABS {Bendix AntiLock Brake System} 4-Channel (4 Sensor/4 Modulator) Full Vehicle Wheel Control System	0/0	0
4GBM	BRAKE, PARKING Manual Push-Pull Pneumatic Parking Brake	1/0	1
4XDP	BRAKES, FRONT {Meritor 16.5X5 Q-PLUS CAST} Air S-Cam Type, Cast Spider, Fabricated Shoe, Double Anchor Pin, Size 16.5" X 5", 14,700-lb Capacity	-23/0	-23
4EXV	BRAKE CHAMBERS, FRONT AXLE {Bendix} 24 Sqli	4/0	4
4LAA	SLACK ADJUSTERS, FRONT {Haldex} Automatic	14/0	14
29331	BRAKE DRUMS, FRONT {Motor Wheel} Centrifuse Type	-30/0	-30
4WBX	DUST SHIELDS, FRONT BRAKE for Air Cam Brakes	10/0	10
4XDR	BRAKES, REAR {Meritor 16.5X7 Q-PLUS CAST} Air S-Cam Type, Cast Spider, Fabricated Shoe, Double Anchor Pin, Size 16.5" X 7", 23,000-lb Capacity per Axle	0/52	52
4EXU	BRAKE CHAMBERS, REAR AXLE {Bendix EverSure} 30/30 Sqli Spring Brake	0/7	7
4LGA	SLACK ADJUSTERS, REAR {Haldex} Automatic	0/16	16
4WDM	DUST SHIELDS, REAR BRAKE for Air Cam Brakes	0/10	10

Code	Description	F/R Wt (lbs)	Tot Wt (lbs)
4SPA	AIR COMPRESSOR {Cummins} 18.7 CFM	0/0	0
4EBD	AIR DRYER {Wabco System Saver 1200} with Heater	7/4	11
4VKC	AIR DRYER LOCATION Mounted Inside Left Rail, Back of Cab	13/8	21
4VKK	AIR TANK LOCATION (2) Mounted Under Battery Box, Outside Right Rail, Back of Cab, Perpendicular to Rail	-15/21	6
4732	DRAIN VALVE {Berg} with Pull Chain, for Air Tank	0/0	0
4619	TRAILER CONNECTIONS Four-Wheel, with Hand Control Valve and Tractor Protection Valve, for Straight Truck	2/0	2

Notes

: When electronic stability control is ordered with trailer connections on a 4x2 truck, please check the operator manual for trailer weight restrictions.

STEERING

5PSA	STEERING GEAR {Sheppard M100} Power	0/0	0
5710	STEERING COLUMN Tilting and Telescoping	17/2	19
5CAW	STEERING WHEEL 4-Spoke; 18" Dia., Black	0/0	0

DRIVELINES

6DGG	DRIVELINE SYSTEM {Dana Spicer} 1710, for 4x2/6x2	6/22	28
------	--	------	----

EXHAUST SYSTEMS

7BLW	EXHAUST SYSTEM Horizontal Aftertreatment System, Frame Mounted Right Side Under Cab, for Single Vertical Tail Pipe, Frame Mounted Right Side Back of Cab	133/44	177
7BEU	AFTERTREATMENT COVER Aluminum	8/3	11
7SCP	ENGINE EXHAUST BRAKE for Cummins ISB/B6.7/ISL/L9 Engine with Variable Vane Turbo Charger	0/0	0
7WDM	EXHAUST HEIGHT 10'	16/12	28
7WDN	MUFFLER/TAIL PIPE GUARD (1) Aluminum	9/7	16
7WAZ	TAIL PIPE (1) Turnback Type	6/4	10

ELECTRICAL SYSTEMS

8000	ELECTRICAL SYSTEM 12-Volt, Standard Equipment	0/0	0
------	---	-----	---

Includes

: DATA LINK CONNECTOR For Vehicle Programming and Diagnostics In Cab
 : HAZARD SWITCH Push On/Push Off, Located on Instrument Panel to Right of Steering Wheel
 : HEADLIGHT DIMMER SWITCH Integral with Turn Signal Lever
 : PARKING LIGHT Integral with Front Turn Signal and Rear Tail Light
 : STARTER SWITCH Electric, Key Operated
 : STOP, TURN, TAIL & B/U LIGHTS Dual, Rear, Combination with Reflector
 : TURN SIGNAL SWITCH Self-Cancelling for Trucks, Manual Cancelling for Tractors, with Lane Change Feature
 : WINDSHIELD WIPER SWITCH 2-Speed with Wash and Intermittent Feature (5 Pre-Set Delays), Integral with Turn Signal Lever

Vehicle Specifications
2027 HV607 SBA (HV607)

<u>Code</u>	<u>Description</u>	<u>F/R Wt</u> (lbs)	<u>Tot Wt</u> (lbs)
	: WINDSHIELD WIPERS Single Motor, Electric, Cowl Mounted : WIRING, CHASSIS Color Coded and Continuously Numbered		
8XHC	ALARM, PARKING BRAKE Electric Horn Sounds in Repetitive Manner when Vehicle Park Brake is "NOT" Set, with Ignition "ON" or "OFF" and any Door Opened and Brake Pedal Released	0/0	0
8GXD	ALTERNATOR {Leece-Neville AVI160P2013} Brush Type, 12 Volt, 160 Amp Capacity, Pad Mount, with Remote Sense	0/0	0
8RPP	ANTENNA Shark Fin, Roof Mounted	1/0	1
8WDG	BACK-UP ALARM {Preco 1059} Electronic; Solid State, Dual Function, 112 dBA	0/1	1
8VUJ	BATTERY BOX Steel, with Plastic Cover, 18" Wide, 2-4 Battery Capacity, Mounted Right Side Back of Cab	-36/13	-23
8XHD	BATTERY DISCONNECT SWITCH 300 Amp, Disconnects Charging Circuits, Locks with Padlock, Cab Mounted	2/0	2
8MJU	BATTERY SYSTEM {Fleetrite} Maintenance-Free, (3) 12-Volt 2850CCA Total, Top Threaded Stud	35/39	74
8VZP	BEACON MOUNTING BRACKET Cab Provision Includes Roof Brackets for Customer Lights and Bracket Mounting	0/0	0
8HAE	BODY BUILDER WIRING Rear of Frame; Includes Sealed Connectors for Tail/ Amber Turn/Marker/ Backup/Accessory Power/Ground and Sealed Connector for Stop/Turn	0/3	3
8XAH	CIRCUIT BREAKERS Manual-Reset (Main Panel) SAE Type III with Trip Indicators, Replaces All Fuses	0/0	0
8518	CIGAR LIGHTER Includes Ash Cup	1/0	1
8WPH	CLEARANCE/MARKER LIGHTS (5) {Truck Lite} Amber LED Lights, Flush Mounted on Cab or Sunshade	0/0	0
8XMB	CONNECTOR, DASH, CENTER PANEL Cab Wiring for TMC RP1226 Vehicle Accessory Connector; Includes 14-pin Connector with Switched Power, Battery Power, Ignition Power, Ground & Body 250K Datalink, Connector Located Behind Instrument Panel Center Console	3/0	3
8HAH	ELECTRIC TRAILER BRAKE/LIGHTS Accommodation Package to Rear of Frame; for Combined Trailer Stop, Tail, Turn, Marker Light Circuits; Includes Electric Trailer Brake Accommodation Package with Cab Connections for Mounting Customer Installed Electric Brake Unit, Less Trailer Socket	0/2	2
8XLG	FUSES, ELECTRICAL (7) Spare Fuses with a Variety of Ratings, Stored in a Module Located Near the Fuse Block, in the Main Fuse Panel Area	0/0	0
8WXB	HEADLIGHT WARNING BUZZER Sounds When Head Light Switch is on and Ignition Switch is in "Off" Position	0/0	0
8XKC	HEADLIGHTS Halogen, with Daytime Running Lights, Automatic Twilight Controlled	0/0	0
8WRB	HEADLIGHTS ON W/WIPERS Headlights Will Automatically Turn On if Windshield Wipers are Turned On	0/0	0
8XHN	HORN, AIR Single Trumpet, Black, with Lanyard Pull Cord	3/0	3
8541	HORN, ELECTRIC (2) Disc Style	1/0	1

Code	Description	F/R Wt (lbs)	Tot Wt (lbs)
8WWJ	INDICATOR, LOW COOLANT LEVEL with Audible Alarm	0/0	0
8WBW	JUMP START STUD 12V, Remote Mounted	2/0	2
8XPK	POWER SOURCE, ADDITIONAL Auxiliary Power Outlet (APO) with USB-A Port and USB-C Port, Located in the Instrument Panel	0/0	0
8RPS	RADIO AM/FM/WB/Clock/Bluetooth/USB Input/Auxiliary Input	3/0	3
8RPB	RADIO, STEERING WHEEL CONTROLS Mounted in Steering Wheel, Radio Function Control Switch, Includes Volume Up/Down, Mute, Forward/Back and Bluetooth Answer/Disconnect	9/1	10
8RMZ	SPEAKERS (2) 6.5" Dual Cone Mounted in Both Doors, (2) 5.25" Dual Cone Mounted in Both B-Pillars	5/3	8
8WXG	STARTING MOTOR {Mitsubishi Electric Automotive America 105P} 12-Volt, with Soft-Start	10/0	10
8XHX	SWITCH, MARKER INTERRUPT for Marker Lights and Headlights, Located in Steering Wheel	0/0	0
8WMA	SWITCH, TOGGLE, FOR WORK LIGHT Lighted; on Instrument Panel and Wiring Effects for Customer Furnished Back of Cab Light	2/1	3
8WPZ	TEST EXTERIOR LIGHTS Pre-Trip Inspection will Cycle all Exterior Lamps Except Back-up Lights	0/0	0
8TKK	TRAILER AUXILIARY FEED CIRCUIT for Electric Trailer Brake Accommodation/ Air Trailer ABS; with 30 Amp Fuse and Relay, Controlled by Ignition Switch	1/0	1
8XGT	TURN SIGNALS, FRONT Includes LED Side Turn Lights Mounted on Fender	0/0	0
8WGL	WINDSHIELD WIPER SPD CONTROL Force Wipers to Slowest Intermittent Speed When Park Brake Set and Wipers Left on for a Predetermined Time	0/0	0
8WJZ	WORKLIGHT ON W/BACKUP Work Lights will Activate when Vehicle is in Reverse	3/0	3

FRONT END

9WBC	FRONT END Tilting, Fiberglass, with Three Piece Construction, for WorkStar/HV	0/0	0
9WAD	BUG DEFLECTOR Smoked Colored Plastic, Mounted on Hood	5/0	5
9WAC	BUG SCREEN Mounted Behind Grille	5/0	5
9585	FENDER EXTENSIONS Rubber	6/0	6
9HBM	GRILLE Stationary, Chrome	0/0	0
9HBN	INSULATION, SPLASH PANELS for Sound Abatement	2/0	2
9HAN	INSULATION, UNDER HOOD for Sound Abatement	10/0	10
9AAB	LOGOS EXTERIOR Model Badges	0/0	0
9AAE	LOGOS EXTERIOR, ENGINE Badges	0/0	0

SPEEDOMETER, TOOLS, MISC

10AGB	CONNECTED PLATFORM Includes Connectivity Module and Five Year Data Plan	1/0	1
10BAE	LABEL, DEF "DEF ONLY"	0/0	0
10060	PAINT SCHEMATIC, PT-1 Single Color, Design 100	0/0	0

15
Vehicle Specifications
2027 HV607 SBA (HV607)

<u>Code</u>	<u>Description</u>	<u>F/R Wt</u> (lbs)	<u>Tot Wt</u> (lbs)
	<u>Includes</u> : PAINT SCHEMATIC ID LETTERS "WL"		
10761	PAINT TYPE Base Coat/Clear Coat, 1-2 Tone	0/0	0

FUEL TANKS

15SGG	FUEL TANK Top Draw, Non-Polished Aluminum, D-Style, 19" Tank Depth, 70 US Gal (265L), Mounted Left Side, Under Cab	8/9	17
15WDG	DEF TANK 7 US Gal (26L) Capacity, Frame Mounted Outside Left Rail, Under Cab	0/0	0
15LNS	FUEL/WATER SEPARATOR {Racor 400 Series} 12 VDC Electric Heater, Includes Pre-Heater, with Primer Pump, Includes Water-in-Fuel Sensor, Mounted on Engine	-1/-4	-5

WHEELS, TIRES - FRONT

27DTU	WHEELS, FRONT {Accuride 29001} DISC; 22.5x7.50 Rims, Powder Coat Steel, 5-Hand Hole, 10-Stud, 285.75mm BC, Hub-Piloted, Flanged Nut, with Steel Hubs	0/0	0
7382135440	(2) TIRE, FRONT 11R22.5 Load Range H HDC 3 (CONTINENTAL), 492 rev/mile, 68 MPH, Drive	28/0	28

WHEELS, TIRES - REAR

28DTT	WHEELS, REAR {Accuride 28828} DUAL DISC; 22.5x8.25 Rims, Powder Coat Steel, 2-Hand Hole, 10-Stud, 285.75mm BC, Hub-Piloted, Flanged Nut, with .472" Thick Increased Capacity Disc and with Steel Hubs	0/28	28
7382135440	(4) TIRE, REAR 11R22.5 Load Range H HDC 3 (CONTINENTAL), 492 rev/mile, 68 MPH, Drive	0/56	56

WHEELS MISC OPTIONS

29ACD	TIRE VALVE CAP Flo-Thru Design	0/0	0
-------	--------------------------------	-----	---

Services Section:

WARRANTY

40128	WARRANTY Standard for HV507/HV509, HV50B, HV607/HV609 Models, Effective with Vehicles Built July 1, 2017 or Later, CTS-2025A	0/0	0
40NSG	CARB COMPANION PLAN for CARB B6.7 and L9 Engines	0/0	0
Total Component Weight:		7663/4955 (lbs)	12618 (lbs)
		(lbs)	(lbs)

The weight calculations included in this proposal are an estimate of future vehicle weight. The actual weight as manufactured may be different from the estimated weight. Navistar, Inc. shall not be liable for any consequences resulting from any differences between the estimated weight of a vehicle and the actual weight.

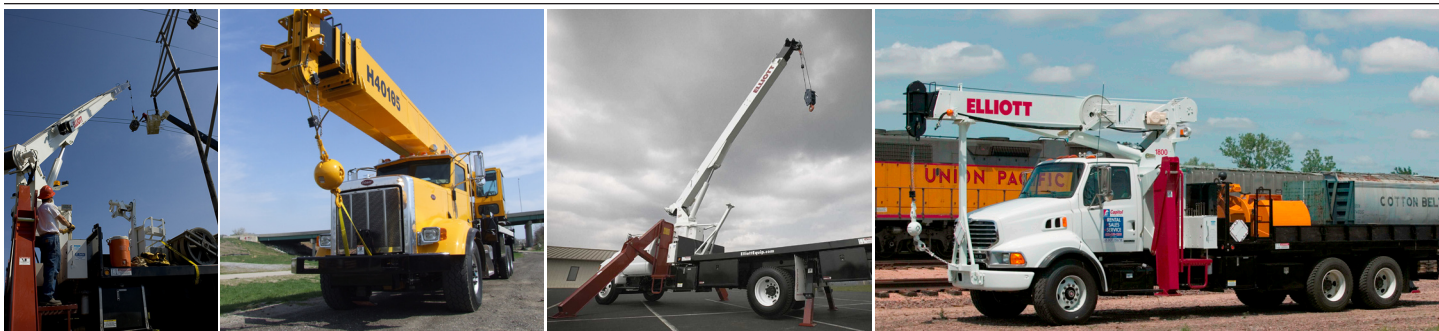

1870F SIDE VIEW DIAGRAM

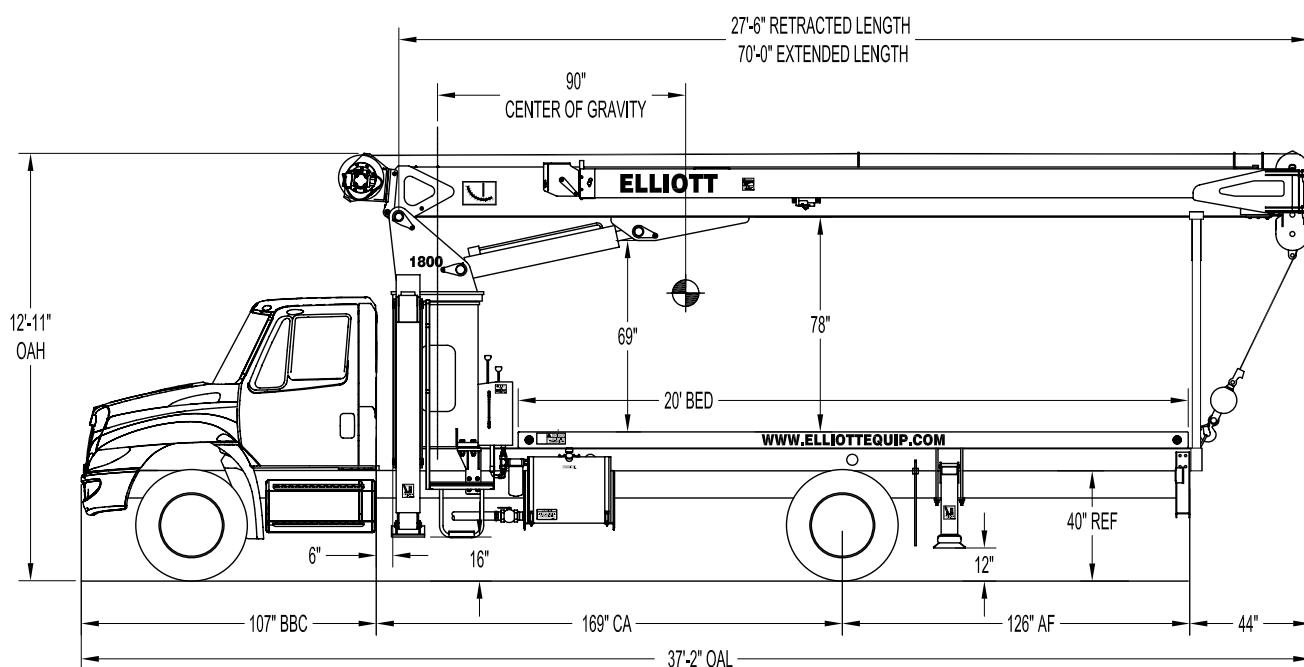

- **Maximum Vertical Reach** 120'/36,6 m
- **Working Area** 180 Degrees Standard (360 Optional)
- **Lifting Capacity** 36,000 lbs/16 329 kg
- **Boom Length** 70'/21,3 m
- **Crane Weight (Dry)** 16,235 lbs/7364 kg
- **Jib Lengths** 23', 23-40'/7 m, 7-12 m
- **Winch Bare Drum Pull** 12,800 lbs/5806 kg

- **Powered Boom Sections** 3
- **Overall Height** 12'11\"/>
- **Operator Controls** Dual Operator Standup Controls
- **Outrigger Type Front** A-Frame
- **Outrigger Spread Front** 20'10\"/>
- **Outrigger Type Rear** A-Underslung
- **Outrigger Spread Rear** 10'4\"/>

TECHNICAL SPECIFICATIONS

Crane Capacity: 36,000 lbs at five feet load radius.

Maximum Tip Height: 80' height (120' with optional 40' jib)

Control Console: Dual operator standup control stations equipped with four single axis control levers for the main crane controls. Operator station includes LMI display, bubble level gauge, engine start/stop switch, signal horn button, variable speed foot throttle, lifting capacity chart, range diagram chart, boom angle indicator, system pressure gauge, 12V DC power source, and cup holder. Outrigger lever controls at control consoles.

Boom: Three-section fully proportional, high strength steel plated rectangular tube sections. A maximum boom tip height of 80' mounted on a truck. The boom nose contains one floating upper sheave and two lower sheaves. Assembly includes heavy-duty cylinder fittings, pivot pins, and replaceable wear pads.

Winch: Mounted at the base of the boom for a long fleet angle and flat level spooling of cable. Winch is driven by a planetary reducer and powered by a hydraulic motor. Burst-of-speed winch provides increased line speed. The winch brake is spring applied, pressure release design. Supplied with 275' of 9/16" wire rope with a single line pull of 9,600 pounds, and a downhaul ball with swivel hook for single part line.

Load Moment Indicator System:

System senses hoist cylinder pressures, boom length and boom angle with hydraulic function lockout. The display console is equipped with a bar graph showing crane utilization, boom angle or boom length, a mode select controls for main boom and jib operation, and an anti-two block with an audio/visual warning and shut-off functions to limit hook-boom point contact.

Outriggers: One set of "A" Frame main outriggers with 20'10" span, and

one set of underslung "A" rear outriggers with a 10'4" span.

Frame: Full length, all welded rigid 4-plate design sub-frame. Sub-frame allows for bolt-on addition of 20' bed.

Turret: Reverse offset turret is one-piece weldment. Turret rotates on large diameter ball bearing.

Rotation: Hydraulic motor drives turret through double reduction planetary swing drive for 372-degree non-continuous rotation. The swing drive system has a spring applied, pressure release brake.

Lift: One double-acting long stroke cylinder provides smooth and stable boom elevation. Holding valve prevents boom from falling in event of hose failure.

Boom Extension: Incorporates a single-stage hydraulic extension cylinder, attached to the largest boom section, with a proportional cable extension system driving the outermost section.

Hoses: All high pressure hoses are wire braid reinforced with a minimum safety factor of 4 to 1.

Cylinders: All cylinders use microhoned cylinder tubing, chrome shafts, top grade packing and protective rod wipers. Cylinder-mounted holding valves provided on all load-holding cylinders.

Hydraulic System: Equipped with cable-shift PTO, three-section gear pump, SAE O-ring face seals on pressure lines, and a 10-micron return line filter. The control valve distributes all flow to hoist system, swing circuit, and other crane functions. System is open center type.

Oil Tank Capacity: 70 gallon mounted to truck frame on roadside.

Cab Equipment: PTO cable with indicator lights installed in truck cab. U/L approved 5:BC dry chemical fire extinguisher installed in truck cab.

Operators Manual & Video: Two CD copies and one hard copy of operation, maintenance, safety and parts manual provided with each unit. Operational and safety video provided at delivery.

Installation: Unit installed on chassis, painted, system and tank filled with oil, tested, inspected, and ready to operate.

Standard Paint: Paint turret and boom white, outriggers red, and bed and boxes black.

Bumper: Bureau of Motor Carrier Safety rear bumper.

Weight: Approximately 15,615 lbs. with 20' steel-floor bed less truck.

Truck Chassis Required: Approx. 168" C.T. RBM 1,463,000 in-lb. per rail, 13,000 lb. front axle and 33,000 lb. GVWR required. Trucks must have front frame extension, 12V electrical system with high capacity alternator, cab clearance stop/tail/backup lights, and I.D. lamps. Recommended GVWR is minimum for BOOMTRUCK with flatbed only. Contact factory when additional equipment is to be added.

Options:

40' or 23' Telescopic Jib.

Radio Remote Controls.

Superlink Short Jack Outriggers.

Gravity Leveled Steel Basket.

Front Jack for 360 Degree Area of Operation.

Rotation Resistant Wire Rope.

Hydraulic Tool Circuits on Bed.

Much more...

Elliott Equipment Company reserves the right to change the specification of any unit at any time without prior notice. This brochure is only a statement of general specifications on the date of this publication. For more detailed info on specific Elliott trucks go to www.elliottequip.com

MAXIMUM LIFTING CAPABILITIES

MAIN BOOM LOAD RATINGS WITH FULLY EXTENDED OUTRIGGERS

MAIN BOOM LOAD RATINGS												JIB LOAD RATINGS						
LOAD RATINGS IN LBS. WITH OUTRIGGERS AND STABILIZERS EXTENDED												LOAD RATINGS IN LBS. WITH OUTRIGGERS AND STABILIZERS EXTENDED						
LOAD RADIUS IN FEET	LOADED BOOM ANGLE	A		B		C		D		E		23-FT FIXED LENGTH JIB			23-40 FT EXTENDABLE JIB			
		27-FT	34-FT	43-FT	52-FT	61-FT	70-FT	LOADED BOOM ANGLE	23-FT JIB	LOADED BOOM ANGLE	23-FT JIB RETRACTED	LOADED BOOM ANGLE	40-FT JIB EXTENDED					
5	79	36000																
10	68	21300	73	19500	77	16500	80	15000				80	4600	80	4500	80	2600	
15	56	15200	64	14500	70	13500	75	12000	78	10500	80	9600	75	3700	75	3600	75	2000
20	41	11500	54	11100	63	10000	69	9000	73	8000	76	7300	70	3000	70	2900	70	1900
25	19	8600	43	8500	55	8000	62	7200	68	6500	71	5800	65	2400	65	2300	65	1800
30			27	6750	47	6400	56	5900	63	5400	67	4900	60	2000	60	1900	60	1300
35					36	5000	49	4700	56	4400	62	4200	55	1600	55	1500	55	900
40					20	4200	41	4100	50	3900	56	3700	50	1400	50	1300	50	800
45							30	3500	43	3400	51	3200	45	1100	45	1000	45	600
50							14	2800	36	2800	45	2700	40	900	40	800		
55									26	2400	39	2300	35	700	35	600		
60											32	1900						
65											22	1550						
	0	6000	0	4200	0	3000	0	1900	0	1300	0	1000						
		340		270		210		170		150		130	DEDUCTIONS FOR STOWED FIXED LENGTH JIB					
		530		420		330		270		230		200	DEDUCTIONS FOR STOWED EXTENDABLE JIB					

NOTICE

- DO NOT DEADHEAD LINE BLOCK AGAINST BOOM TIP WHEN EXTENDING BOOM

- KEEP AT LEAST 5 WRAPS OF LOADLINE ON THE WINCH DRUM AT ALL TIMES

- USE ONLY 9/16" DIAMETER WIRE ROPE, AS SPECIFIED BELOW, WITH THE PROPER BREAKING STRENGTHS LISTED

- ANTI-TWO-BLOCK SYSTEM MUST BE IN GOOD OPERATING CONDITION BEFORE OPERATING CRANE. SEE OPERATION & SAFETY MANUAL

1-PART LINE



2-PART LINE



3-PART LINE



4-PART LINE



ELLIOTT EQUIPMENT CO. SUPPLIED LOADLINE EQUIPMENT DEDUCTIONS:
 DOWNHAUL WEIGHT180 lbs
 ONE SHEAVE BLOCK.....375 lbs
 TWO SHEAVE BLOCK.....640 lbs

MAX PULL: 9,600 lbs	19,200 lbs	28,800 lbs	36,000 lbs	9/16" - 6 x 37 IWRC (3.5:1 S.F.) 33,600-lbs. BREAKING STRENGTH
MAX PULL: 9,060 lbs	18,120 lbs	27,180 lbs	36,000 lbs	9/16" - SPIN RESISTANT (5:1 S.F.) 45,300-lbs. BREAKING STRENGTH
MAX PULL: 7,680 lbs	15,360 lbs	23,040 lbs	30,720 lbs	9/16" - SPIN RESISTANT (5:1 S.F.) 38,400-lbs. BREAKING STRENGTH

CRANE MEETS ASME B30.5 REQUIREMENTS AT TIME OF MANUFACTURE

DO NOT PAINT OVER ANY LABELS 1080270 043004



Elliott Equipment Company
 3514 South 25th Street
 Omaha, NE 68105
 Phone: 402-592-4500
 Fax: 402-592-4553
 Email: sales@elliottequip.com

Built for You.
 www.elliottequip.com

MAXIMUM RANGE CAPABILITIES

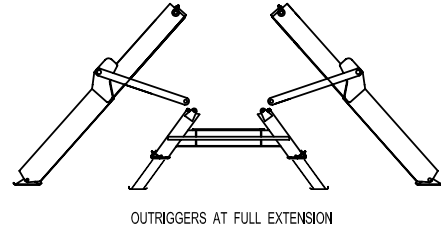
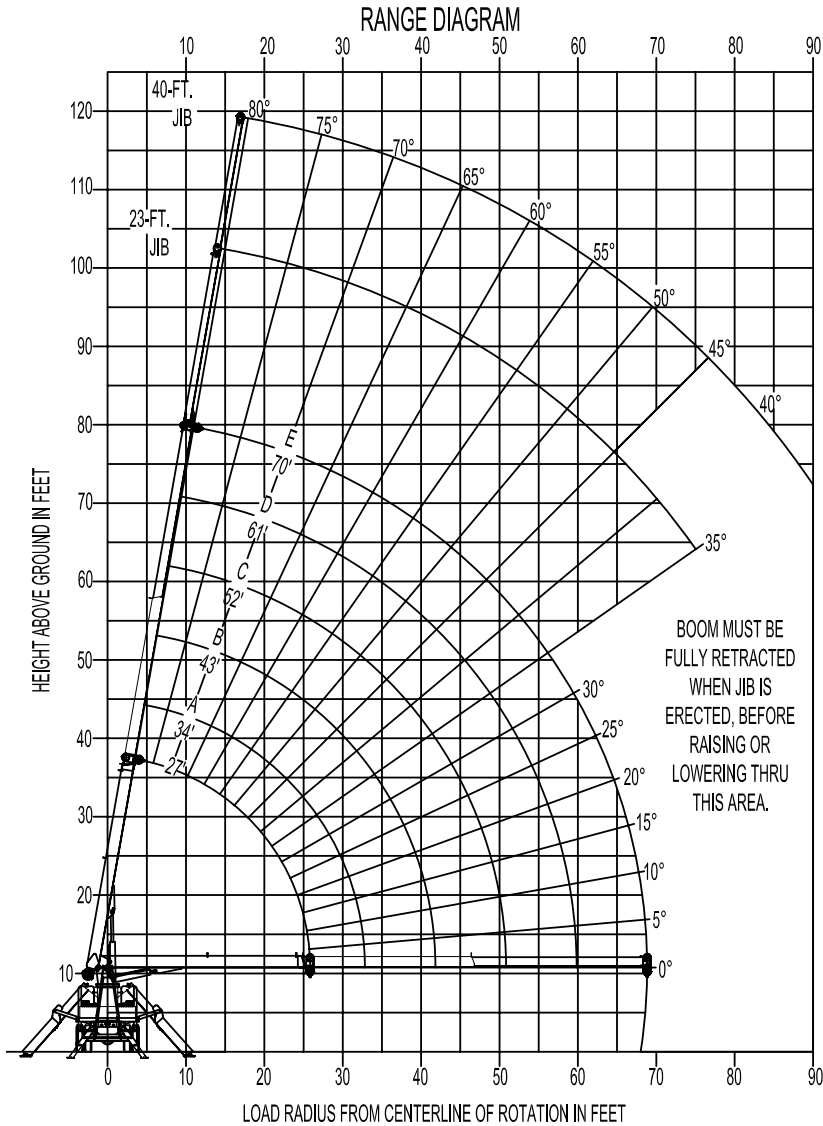

NOTE:

1. Operate jib by radius when main boom is full extended. Increase boom angle if necessary to maintain load radius.
2. When boom is retracted, operate jib by boom angles. Do not exceed any rated jib capacities at reduced boom lengths.
3. Capacities do not exceed 85% stability.
4. Load ratings above bold line are structurally limited.
5. Personnel handling is allowed only with full span outriggers.
6. Boom load ratings are based on loaded boom radius. Loaded boom angles are given as reference only.

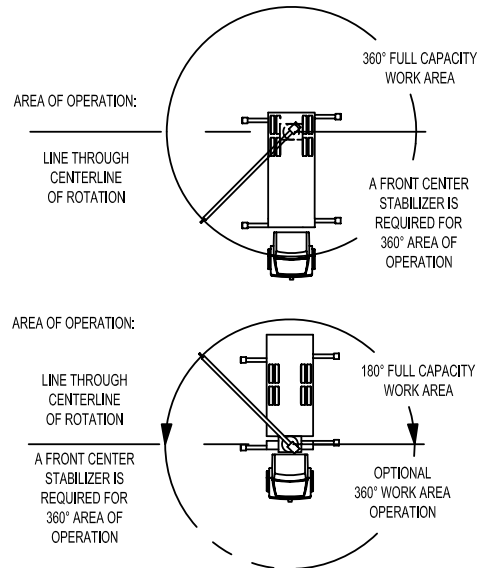

CHASSIS SPECIFICATIONS

	1870F BoomTruck
Wheelbase (WB)	236" / 599 cm
Cab to Axle (CA)	168" / 427 cm
Cab to End of Frame (EOF)	295" / 749 cm
Frame Section Modulus	13.3 in3-110,000 psi / 758,428 kPa
Front Axle Gross Weight Rating	13,000 lb / 5896 kg
Rear Axle Gross Weight Rating	20,000 lb / 9072 kg
Integral Front Frame Rails	Required for Front Stabilizer

Chassis data is minimum general requirements-not for engineering.
Actual dimensions and truck data will depend on truck selection and axle configuration.
*Minimum chassis weight is required to meet 85% stability requirements.

OPTIONS

**Radio Remote Control**

Interference protected radio remotes let you get closer to your work and have full control over your machine.

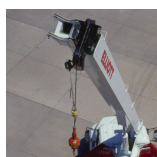
**Pin-On Jib Attachments**

One piece & two piece telescoping or fixed jibs that stow on the side of the boom for easy placement while on the worksite.

**Continuous Boom Rotation**

Add the convenience of 360 degree area of operation by adding a special boom rotation bearing for swinging without stops.

**Superlink Short Jack Outriggers**

Reduce your outrigger spread with Elliott's patented Superlink outriggers that allow straight down outrigger deployment on one side and full crane operation on the other.

**Tool Boxes**

Optional tool boxes and bed storage can accommodate any storage need for tools, work materials and more.

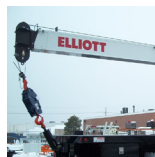
**Hook Block for Multi-Part Line**

Elliott can install a 2-3 part hook block or a 4 part-hook block to improve lifting capabilities. The block can be stored at the rear of the bed.

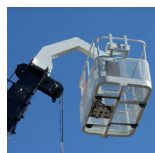
**Gravity Levelled Basket**

Elliott's pin-on work platform pins onto the boom for easy installation and removal. Gravity leveling and mechanical rotation makes it a great accessory for any worksite.

**Body Mounted Hose Reels and Circuits**

Let us work with you to customize your tool compatibility by adding hose reels or hydraulic circuits to the crane bed.

**Solicitation Number: RFP #110421****CONTRACT**

This Contract is between Sourcewell, 202 12th Street Northeast, P.O. Box 219, Staples, MN 56479 (Sourcewell) and Elliott Equipment Company, 3514 South 25th Street, Omaha, NE 68105 (Supplier).

Sourcewell is a State of Minnesota local government unit and service cooperative created under the laws of the State of Minnesota (Minnesota Statutes Section 123A.21) that offers cooperative procurement solutions to government entities. Participation is open to eligible federal, state/province, and municipal governmental entities, higher education, K-12 education, nonprofit, tribal government, and other public entities located in the United States and Canada. Sourcewell issued a public solicitation for Public Utility Equipment with Related Accessories and Supplies from which Supplier was awarded a contract.

Supplier desires to contract with Sourcewell to provide equipment, products, or services to Sourcewell and the entities that access Sourcewell's cooperative purchasing contracts (Participating Entities).

1. TERM OF CONTRACT

- A. **EFFECTIVE DATE.** This Contract is effective upon the date of the final signature below.
- B. **EXPIRATION DATE AND EXTENSION.** This Contract expires December 27, 2025, unless it is cancelled sooner pursuant to Article 22. This Contract may be extended one additional year upon the request of Sourcewell and written agreement by Supplier.
- C. **SURVIVAL OF TERMS.** Notwithstanding any expiration or termination of this Contract, all payment obligations incurred prior to expiration or termination will survive, as will the following: Articles 11 through 14 survive the expiration or cancellation of this Contract. All other rights will cease upon expiration or termination of this Contract.

2. EQUIPMENT, PRODUCTS, OR SERVICES

- A. **EQUIPMENT, PRODUCTS, OR SERVICES.** Supplier will provide the Equipment, Products, or Services as stated in its Proposal submitted under the Solicitation Number listed above.

Supplier's Equipment, Products, or Services Proposal (Proposal) is attached and incorporated into this Contract.

All Equipment and Products provided under this Contract must be new and the current model. Supplier may offer close-out or refurbished Equipment or Products if they are clearly indicated in Supplier's product and pricing list. Unless agreed to by the Participating Entities in advance, Equipment or Products must be delivered as operational to the Participating Entity's site.

This Contract offers an indefinite quantity of sales, and while substantial volume is anticipated, sales and sales volume are not guaranteed.

B. **WARRANTY.** Supplier warrants that all Equipment, Products, and Services furnished are free from liens and encumbrances, and are free from defects in design, materials, and workmanship. In addition, Supplier warrants the Equipment, Products, and Services are suitable for and will perform in accordance with the ordinary use for which they are intended. Supplier's dealers and distributors must agree to assist the Participating Entity in reaching a resolution in any dispute over warranty terms with the manufacturer. Any manufacturer's warranty that extends beyond the expiration of the Supplier's warranty will be passed on to the Participating Entity.

C. **DEALERS, DISTRIBUTORS, AND/OR RESELLERS.** Upon Contract execution and throughout the Contract term, Supplier must provide to Sourcewell a current means to validate or authenticate Supplier's authorized dealers, distributors, or resellers relative to the Equipment, Products, and Services offered under this Contract, which will be incorporated into this Contract by reference. It is the Supplier's responsibility to ensure Sourcewell receives the most current information.

3. PRICING

All Equipment, Products, or Services under this Contract will be priced at or below the price stated in Supplier's Proposal.

When providing pricing quotes to Participating Entities, all pricing quoted must reflect a Participating Entity's total cost of acquisition. This means that the quoted cost is for delivered Equipment, Products, and Services that are operational for their intended purpose, and includes all costs to the Participating Entity's requested delivery location.

Regardless of the payment method chosen by the Participating Entity, the total cost associated with any purchase option of the Equipment, Products, or Services must always be disclosed in the pricing quote to the applicable Participating Entity at the time of purchase.

A. **SHIPPING AND SHIPPING COSTS.** All delivered Equipment and Products must be properly packaged. Damaged Equipment and Products may be rejected. If the damage is not readily apparent at the time of delivery, Supplier must permit the Equipment and Products to be

returned within a reasonable time at no cost to Sourcewell or its Participating Entities. Participating Entities reserve the right to inspect the Equipment and Products at a reasonable time after delivery where circumstances or conditions prevent effective inspection of the Equipment and Products at the time of delivery. In the event of the delivery of nonconforming Equipment and Products, the Participating Entity will notify the Supplier as soon as possible and the Supplier will replace nonconforming Equipment and Products with conforming Equipment and Products that are acceptable to the Participating Entity.

Supplier must arrange for and pay for the return shipment on Equipment and Products that arrive in a defective or inoperable condition.

Sourcewell may declare the Supplier in breach of this Contract if the Supplier intentionally delivers substandard or inferior Equipment or Products.

B. SALES TAX. Each Participating Entity is responsible for supplying the Supplier with valid tax-exemption certification(s). When ordering, a Participating Entity must indicate if it is a tax-exempt entity.

C. HOT LIST PRICING. At any time during this Contract, Supplier may offer a specific selection of Equipment, Products, or Services at discounts greater than those listed in the Contract. When Supplier determines it will offer Hot List Pricing, it must be submitted electronically to Sourcewell in a line-item format. Equipment, Products, or Services may be added or removed from the Hot List at any time through a Sourcewell Price and Product Change Form as defined in Article 4 below.

Hot List program and pricing may also be used to discount and liquidate close-out and discontinued Equipment and Products as long as those close-out and discontinued items are clearly identified as such. Current ordering process and administrative fees apply. Hot List Pricing must be published and made available to all Participating Entities.

4. PRODUCT AND PRICING CHANGE REQUESTS

Supplier may request Equipment, Product, or Service changes, additions, or deletions at any time. All requests must be made in writing by submitting a signed Sourcewell Price and Product Change Request Form to the assigned Sourcewell Supplier Development Administrator. This approved form is available from the assigned Sourcewell Supplier Development Administrator. At a minimum, the request must:

- Identify the applicable Sourcewell contract number;
- Clearly specify the requested change;
- Provide sufficient detail to justify the requested change;

- Individually list all Equipment, Products, or Services affected by the requested change, along with the requested change (e.g., addition, deletion, price change); and
- Include a complete restatement of pricing documentation in Microsoft Excel with the effective date of the modified pricing, or product addition or deletion. The new pricing restatement must include all Equipment, Products, and Services offered, even for those items where pricing remains unchanged.

A fully executed Sourcewell Price and Product Change Request Form will become an amendment to this Contract and will be incorporated by reference.

5. PARTICIPATION, CONTRACT ACCESS, AND PARTICIPATING ENTITY REQUIREMENTS

A. PARTICIPATION. Sourcewell's cooperative contracts are available and open to public and nonprofit entities across the United States and Canada; such as federal, state/province, municipal, K-12 and higher education, tribal government, and other public entities.

The benefits of this Contract should be available to all Participating Entities that can legally access the Equipment, Products, or Services under this Contract. A Participating Entity's authority to access this Contract is determined through its cooperative purchasing, interlocal, or joint powers laws. Any entity accessing benefits of this Contract will be considered a Service Member of Sourcewell during such time of access. Supplier understands that a Participating Entity's use of this Contract is at the Participating Entity's sole convenience and Participating Entities reserve the right to obtain like Equipment, Products, or Services from any other source.

Supplier is responsible for familiarizing its sales and service forces with Sourcewell contract use eligibility requirements and documentation and will encourage potential participating entities to join Sourcewell. Sourcewell reserves the right to add and remove Participating Entities to its roster during the term of this Contract.

B. PUBLIC FACILITIES. Supplier's employees may be required to perform work at government-owned facilities, including schools. Supplier's employees and agents must conduct themselves in a professional manner while on the premises, and in accordance with Participating Entity policies and procedures, and all applicable laws.

6. PARTICIPATING ENTITY USE AND PURCHASING

A. ORDERS AND PAYMENT. To access the contracted Equipment, Products, or Services under this Contract, a Participating Entity must clearly indicate to Supplier that it intends to access this Contract; however, order flow and procedure will be developed jointly between Sourcewell and Supplier. Typically, a Participating Entity will issue an order directly to Supplier or its authorized subsidiary, distributor, dealer, or reseller. If a Participating Entity issues a purchase order, it may use its own forms, but the purchase order should clearly note the applicable Sourcewell

contract number. All Participating Entity orders under this Contract must be issued prior to expiration or cancellation of this Contract; however, Supplier performance, Participating Entity payment obligations, and any applicable warranty periods or other Supplier or Participating Entity obligations may extend beyond the term of this Contract.

Supplier's acceptable forms of payment are included in its attached Proposal. Participating Entities will be solely responsible for payment and Sourcewell will have no liability for any unpaid invoice of any Participating Entity.

B. **ADDITIONAL TERMS AND CONDITIONS/PARTICIPATING ADDENDUM.** Additional terms and conditions to a purchase order, or other required transaction documentation, may be negotiated between a Participating Entity and Supplier, such as job or industry-specific requirements, legal requirements (e.g., affirmative action or immigration status requirements), or specific local policy requirements. Some Participating Entities may require the use of a Participating Addendum; the terms of which will be negotiated directly between the Participating Entity and the Supplier. Any negotiated additional terms and conditions must never be less favorable to the Participating Entity than what is contained in this Contract.

C. **SPECIALIZED SERVICE REQUIREMENTS.** In the event that the Participating Entity requires service or specialized performance requirements not addressed in this Contract (such as e-commerce specifications, specialized delivery requirements, or other specifications and requirements), the Participating Entity and the Supplier may enter into a separate, standalone agreement, apart from this Contract. Sourcewell, including its agents and employees, will not be made a party to a claim for breach of such agreement.

D. **TERMINATION OF ORDERS.** Participating Entities may terminate an order, in whole or in part, immediately upon notice to Supplier in the event of any of the following events:

1. The Participating Entity fails to receive funding or appropriation from its governing body at levels sufficient to pay for the equipment, products, or services to be purchased; or
2. Federal, state, or provincial laws or regulations prohibit the purchase or change the Participating Entity's requirements.

E. **GOVERNING LAW AND VENUE.** The governing law and venue for any action related to a Participating Entity's order will be determined by the Participating Entity making the purchase.

7. CUSTOMER SERVICE

A. **PRIMARY ACCOUNT REPRESENTATIVE.** Supplier will assign an Account Representative to Sourcewell for this Contract and must provide prompt notice to Sourcewell if that person is changed. The Account Representative will be responsible for:

- Maintenance and management of this Contract;
- Timely response to all Sourcwell and Participating Entity inquiries; and
- Business reviews to Sourcwell and Participating Entities, if applicable.

B. BUSINESS REVIEWS. Supplier must perform a minimum of one business review with Sourcwell per contract year. The business review will cover sales to Participating Entities, pricing and contract terms, administrative fees, sales data reports, supply issues, customer issues, and any other necessary information.

8. REPORT ON CONTRACT SALES ACTIVITY AND ADMINISTRATIVE FEE PAYMENT

A. CONTRACT SALES ACTIVITY REPORT. Each calendar quarter, Supplier must provide a contract sales activity report (Report) to the Sourcwell Supplier Development Administrator assigned to this Contract. Reports are due no later than 45 days after the end of each calendar quarter. A Report must be provided regardless of the number or amount of sales during that quarter (i.e., if there are no sales, Supplier must submit a report indicating no sales were made).

The Report must contain the following fields:

- Participating Entity Name (e.g., City of Staples Highway Department);
- Participating Entity Physical Street Address;
- Participating Entity City;
- Participating Entity State/Province;
- Participating Entity Zip/Postal Code;
- Participating Entity Contact Name;
- Participating Entity Contact Email Address;
- Participating Entity Contact Telephone Number;
- Sourcwell Assigned Entity/Participating Entity Number;
- Item Purchased Description;
- Item Purchased Price;
- Sourcwell Administrative Fee Applied; and
- Date Purchase was invoiced/sale was recognized as revenue by Supplier.

B. ADMINISTRATIVE FEE. In consideration for the support and services provided by Sourcwell, the Supplier will pay an administrative fee to Sourcwell on all Equipment, Products, and Services provided to Participating Entities. The Administrative Fee must be included in, and not added to, the pricing. Supplier may not charge Participating Entities more than the contracted price to offset the Administrative Fee.

The Supplier will submit payment to Sourcwell for the percentage of administrative fee stated in the Proposal multiplied by the total sales of all Equipment, Products, and Services purchased

by Participating Entities under this Contract during each calendar quarter. Payments should note the Supplier's name and Sourcewell-assigned contract number in the memo; and must be mailed to the address above "Attn: Accounts Receivable" or remitted electronically to Sourcewell's banking institution per Sourcewell's Finance department instructions. Payments must be received no later than 45 calendar days after the end of each calendar quarter.

Supplier agrees to cooperate with Sourcewell in auditing transactions under this Contract to ensure that the administrative fee is paid on all items purchased under this Contract.

In the event the Supplier is delinquent in any undisputed administrative fees, Sourcewell reserves the right to cancel this Contract and reject any proposal submitted by the Supplier in any subsequent solicitation. In the event this Contract is cancelled by either party prior to the Contract's expiration date, the administrative fee payment will be due no more than 30 days from the cancellation date.

9. AUTHORIZED REPRESENTATIVE

Sourcewell's Authorized Representative is its Chief Procurement Officer.

Supplier's Authorized Representative is the person named in the Supplier's Proposal. If Supplier's Authorized Representative changes at any time during this Contract, Supplier must promptly notify Sourcewell in writing.

10. AUDIT, ASSIGNMENT, AMENDMENTS, WAIVER, AND CONTRACT COMPLETE

A. **AUDIT.** Pursuant to Minnesota Statutes Section 16C.05, subdivision 5, the books, records, documents, and accounting procedures and practices relevant to this Agreement are subject to examination by Sourcewell or the Minnesota State Auditor for a minimum of six years from the end of this Contract. This clause extends to Participating Entities as it relates to business conducted by that Participating Entity under this Contract.

B. **ASSIGNMENT.** Neither party may assign or otherwise transfer its rights or obligations under this Contract without the prior written consent of the other party and a fully executed assignment agreement. Such consent will not be unreasonably withheld. Any prohibited assignment will be invalid.

C. **AMENDMENTS.** Any amendment to this Contract must be in writing and will not be effective until it has been duly executed by the parties.

D. **WAIVER.** Failure by either party to take action or assert any right under this Contract will not be deemed a waiver of such right in the event of the continuation or repetition of the circumstances giving rise to such right. Any such waiver must be in writing and signed by the parties.

E. **CONTRACT COMPLETE.** This Contract represents the complete agreement between the parties. No other understanding regarding this Contract, whether written or oral, may be used to bind either party. For any conflict between the attached Proposal and the terms set out in Articles 1-22 of this Contract, the terms of Articles 1-22 will govern.

F. **RELATIONSHIP OF THE PARTIES.** The relationship of the parties is one of independent contractors, each free to exercise judgment and discretion with regard to the conduct of their respective businesses. This Contract does not create a partnership, joint venture, or any other relationship such as master-servant, or principal-agent.

11. INDEMNITY AND HOLD HARMLESS

Supplier must indemnify, defend, save, and hold Sourcewell and its Participating Entities, including their agents and employees, harmless from any claims or causes of action, including attorneys' fees incurred by Sourcewell or its Participating Entities, arising out of any act or omission in the performance of this Contract by the Supplier or its agents or employees; this indemnification includes injury or death to person(s) or property alleged to have been caused by some defect in the Equipment, Products, or Services under this Contract to the extent the Equipment, Product, or Service has been used according to its specifications. Sourcewell's responsibility will be governed by the State of Minnesota's Tort Liability Act (Minnesota Statutes Chapter 466) and other applicable law.

12. GOVERNMENT DATA PRACTICES

Supplier and Sourcewell must comply with the Minnesota Government Data Practices Act, Minnesota Statutes Chapter 13, as it applies to all data provided by or provided to Sourcewell under this Contract and as it applies to all data created, collected, received, stored, used, maintained, or disseminated by the Supplier under this Contract.

13. INTELLECTUAL PROPERTY, PUBLICITY, MARKETING, AND ENDORSEMENT

A. INTELLECTUAL PROPERTY

1. *Grant of License.* During the term of this Contract:
 - a. Sourcewell grants to Supplier a royalty-free, worldwide, non-exclusive right and license to use the trademark(s) provided to Supplier by Sourcewell in advertising and promotional materials for the purpose of marketing Sourcewell's relationship with Supplier.
 - b. Supplier grants to Sourcewell a royalty-free, worldwide, non-exclusive right and license to use Supplier's trademarks in advertising and promotional materials for the purpose of marketing Supplier's relationship with Sourcewell.
2. *Limited Right of Sublicense.* The right and license granted herein includes a limited right of each party to grant sublicenses to their respective subsidiaries, distributors, dealers,

resellers, marketing representatives, and agents (collectively “Permitted Sublicensees”) in advertising and promotional materials for the purpose of marketing the Parties’ relationship to Participating Entities. Any sublicense granted will be subject to the terms and conditions of this Article. Each party will be responsible for any breach of this Article by any of their respective sublicensees.

3. Use; Quality Control.

- a. Neither party may alter the other party’s trademarks from the form provided and must comply with removal requests as to specific uses of its trademarks or logos.
- b. Each party agrees to use, and to cause its Permitted Sublicensees to use, the other party’s trademarks only in good faith and in a dignified manner consistent with such party’s use of the trademarks. Upon written notice to the breaching party, the breaching party has 30 days of the date of the written notice to cure the breach or the license will be terminated.

4. As applicable, Supplier agrees to indemnify and hold harmless Sourcewell and its Participating Entities against any and all suits, claims, judgments, and costs instituted or recovered against Sourcewell or Participating Entities by any person on account of the use of any Equipment or Products by Sourcewell or its Participating Entities supplied by Supplier in violation of applicable patent or copyright laws.

5. Termination. Upon the termination of this Contract for any reason, each party, including Permitted Sublicensees, will have 30 days to remove all Trademarks from signage, websites, and the like bearing the other party’s name or logo (excepting Sourcewell’s pre-printed catalog of suppliers which may be used until the next printing). Supplier must return all marketing and promotional materials, including signage, provided by Sourcewell, or dispose of it according to Sourcewell’s written directions.

B. **PUBLICITY.** Any publicity regarding the subject matter of this Contract must not be released without prior written approval from the Authorized Representatives. Publicity includes notices, informational pamphlets, press releases, research, reports, signs, and similar public notices prepared by or for the Supplier individually or jointly with others, or any subcontractors, with respect to the program, publications, or services provided resulting from this Contract.

C. **MARKETING.** Any direct advertising, marketing, or offers with Participating Entities must be approved by Sourcewell. Send all approval requests to the Sourcewell Supplier Development Administrator assigned to this Contract.

D. **ENDORSEMENT.** The Supplier must not claim that Sourcewell endorses its Equipment, Products, or Services.

14. GOVERNING LAW, JURISDICTION, AND VENUE

The substantive and procedural laws of the State of Minnesota will govern this Contract. Venue for all legal proceedings arising out of this Contract, or its breach, must be in the appropriate state court in Todd County, Minnesota or federal court in Fergus Falls, Minnesota.

15. FORCE MAJEURE

Neither party to this Contract will be held responsible for delay or default caused by acts of God or other conditions that are beyond that party's reasonable control. A party defaulting under this provision must provide the other party prompt written notice of the default.

16. SEVERABILITY

If any provision of this Contract is found by a court of competent jurisdiction to be illegal, unenforceable, or void then both parties will be relieved from all obligations arising from that provision. If the remainder of this Contract is capable of being performed, it will not be affected by such determination or finding and must be fully performed.

17. PERFORMANCE, DEFAULT, AND REMEDIES

A. **PERFORMANCE.** During the term of this Contract, the parties will monitor performance and address unresolved contract issues as follows:

1. *Notification.* The parties must promptly notify each other of any known dispute and work in good faith to resolve such dispute within a reasonable period of time. If necessary, Sourcewell and the Supplier will jointly develop a short briefing document that describes the issue(s), relevant impact, and positions of both parties.
2. *Escalation.* If parties are unable to resolve the issue in a timely manner, as specified above, either Sourcewell or Supplier may escalate the resolution of the issue to a higher level of management. The Supplier will have 30 calendar days to cure an outstanding issue.
3. *Performance while Dispute is Pending.* Notwithstanding the existence of a dispute, the Supplier must continue without delay to carry out all of its responsibilities under the Contract that are not affected by the dispute. If the Supplier fails to continue without delay to perform its responsibilities under the Contract, in the accomplishment of all undisputed work, the Supplier will bear any additional costs incurred by Sourcewell and/or its Participating Entities as a result of such failure to proceed.

B. **DEFAULT AND REMEDIES.** Either of the following constitutes cause to declare this Contract, or any Participating Entity order under this Contract, in default:

1. Nonperformance of contractual requirements, or
2. A material breach of any term or condition of this Contract.

The party claiming default must provide written notice of the default, with 30 calendar days to cure the default. Time allowed for cure will not diminish or eliminate any liability for liquidated or other damages. If the default remains after the opportunity for cure, the non-defaulting party may:

- Exercise any remedy provided by law or equity, or
- Terminate the Contract or any portion thereof, including any orders issued against the Contract.

18. INSURANCE

A. REQUIREMENTS. At its own expense, Supplier must maintain insurance policy(ies) in effect at all times during the performance of this Contract with insurance company(ies) licensed or authorized to do business in the State of Minnesota having an "AM BEST" rating of A- or better, with coverage and limits of insurance not less than the following:

1. *Workers' Compensation and Employer's Liability.*

Workers' Compensation: As required by any applicable law or regulation.

Employer's Liability Insurance: must be provided in amounts not less than listed below:

Minimum limits:

\$500,000 each accident for bodily injury by accident

\$500,000 policy limit for bodily injury by disease

\$500,000 each employee for bodily injury by disease

2. *Commercial General Liability Insurance.* Supplier will maintain insurance covering its operations, with coverage on an occurrence basis, and must be subject to terms no less broad than the Insurance Services Office ("ISO") Commercial General Liability Form CG0001 (2001 or newer edition), or equivalent. At a minimum, coverage must include liability arising from premises, operations, bodily injury and property damage, independent contractors, products-completed operations including construction defect, contractual liability, blanket contractual liability, and personal injury and advertising injury. All required limits, terms and conditions of coverage must be maintained during the term of this Contract.

Minimum Limits:

\$1,000,000 each occurrence Bodily Injury and Property Damage

\$1,000,000 Personal and Advertising Injury

\$2,000,000 aggregate for Products-Completed operations

\$2,000,000 general aggregate

3. *Commercial Automobile Liability Insurance.* During the term of this Contract, Supplier will maintain insurance covering all owned, hired, and non-owned automobiles in limits of liability not less than indicated below. The coverage must be subject to terms

no less broad than ISO Business Auto Coverage Form CA 0001 (2010 edition or newer), or equivalent.

Minimum Limits:

\$1,000,000 each accident, combined single limit

4. *Umbrella Insurance*. During the term of this Contract, Supplier will maintain umbrella coverage over Employer's Liability, Commercial General Liability, and Commercial Automobile.

Minimum Limits:

\$2,000,000

5. *Network Security and Privacy Liability Insurance*. During the term of this Contract, Supplier will maintain coverage for network security and privacy liability. The coverage may be endorsed on another form of liability coverage or written on a standalone policy. The insurance must cover claims which may arise from failure of Supplier's security resulting in, but not limited to, computer attacks, unauthorized access, disclosure of not public data – including but not limited to, confidential or private information, transmission of a computer virus, or denial of service.

Minimum limits:

\$2,000,000 per occurrence

\$2,000,000 annual aggregate

Failure of Supplier to maintain the required insurance will constitute a material breach entitling Sourcewell to immediately terminate this Contract for default.

B. CERTIFICATES OF INSURANCE. Prior to commencing under this Contract, Supplier must furnish to Sourcewell a certificate of insurance, as evidence of the insurance required under this Contract. Prior to expiration of the policy(ies), renewal certificates must be mailed to Sourcewell, 202 12th Street Northeast, P.O. Box 219, Staples, MN 56479 or sent to the Sourcewell Supplier Development Administrator assigned to this Contract. The certificates must be signed by a person authorized by the insurer(s) to bind coverage on their behalf.

Failure to request certificates of insurance by Sourcewell, or failure of Supplier to provide certificates of insurance, in no way limits or relieves Supplier of its duties and responsibilities in this Contract.

C. ADDITIONAL INSURED ENDORSEMENT AND PRIMARY AND NON-CONTRIBUTORY INSURANCE CLAUSE. Supplier agrees to list Sourcewell and its Participating Entities, including their officers, agents, and employees, as an additional insured under the Supplier's commercial general liability insurance policy with respect to liability arising out of activities, "operations," or "work" performed by or on behalf of Supplier, and products and completed operations of Supplier. The policy provision(s) or endorsement(s) must further provide that coverage is

primary and not excess over or contributory with any other valid, applicable, and collectible insurance or self-insurance in force for the additional insureds.

D. **WAIVER OF SUBROGATION.** Supplier waives and must require (by endorsement or otherwise) all its insurers to waive subrogation rights against Sourcewell and other additional insureds for losses paid under the insurance policies required by this Contract or other insurance applicable to the Supplier or its subcontractors. The waiver must apply to all deductibles and/or self-insured retentions applicable to the required or any other insurance maintained by the Supplier or its subcontractors. Where permitted by law, Supplier must require similar written express waivers of subrogation and insurance clauses from each of its subcontractors.

E. **UMBRELLA/EXCESS LIABILITY/SELF-INSURED RETENTION.** The limits required by this Contract can be met by either providing a primary policy or in combination with umbrella/excess liability policy(ies), or self-insured retention.

19. COMPLIANCE

A. **LAWS AND REGULATIONS.** All Equipment, Products, or Services provided under this Contract must comply fully with applicable federal laws and regulations, and with the laws in the states and provinces in which the Equipment, Products, or Services are sold.

B. **LICENSES.** Supplier must maintain a valid and current status on all required federal, state/provincial, and local licenses, bonds, and permits required for the operation of the business that the Supplier conducts with Sourcewell and Participating Entities.

20. BANKRUPTCY, DEBARMENT, OR SUSPENSION CERTIFICATION

Supplier certifies and warrants that it is not in bankruptcy or that it has previously disclosed in writing certain information to Sourcewell related to bankruptcy actions. If at any time during this Contract Supplier declares bankruptcy, Supplier must immediately notify Sourcewell in writing.

Supplier certifies and warrants that neither it nor its principals are presently debarred, suspended, proposed for debarment, declared ineligible, or voluntarily excluded from programs operated by the State of Minnesota; the United States federal government or the Canadian government, as applicable; or any Participating Entity. Supplier certifies and warrants that neither it nor its principals have been convicted of a criminal offense related to the subject matter of this Contract. Supplier further warrants that it will provide immediate written notice to Sourcewell if this certification changes at any time.

21. PROVISIONS FOR NON-UNITED STATES FEDERAL ENTITY PROCUREMENTS UNDER UNITED STATES FEDERAL AWARDS OR OTHER AWARDS

Participating Entities that use United States federal grant or FEMA funds to purchase goods or services from this Contract may be subject to additional requirements including the procurement standards of the Uniform Administrative Requirements, Cost Principles and Audit Requirements for Federal Awards, 2 C.F.R. § 200. Participating Entities may have additional requirements based on specific funding source terms or conditions. Within this Article, all references to “federal” should be interpreted to mean the United States federal government. The following list only applies when a Participating Entity accesses Supplier’s Equipment, Products, or Services with United States federal funds.

A. **EQUAL EMPLOYMENT OPPORTUNITY.** Except as otherwise provided under 41 C.F.R. § 60, all contracts that meet the definition of “federally assisted construction contract” in 41 C.F.R. § 60-1.3 must include the equal opportunity clause provided under 41 C.F.R. §60-1.4(b), in accordance with Executive Order 11246, “Equal Employment Opportunity” (30 FR 12319, 12935, 3 C.F.R. §, 1964-1965 Comp., p. 339), as amended by Executive Order 11375, “Amending Executive Order 11246 Relating to Equal Employment Opportunity,” and implementing regulations at 41 C.F.R. § 60, “Office of Federal Contract Compliance Programs, Equal Employment Opportunity, Department of Labor.” The equal opportunity clause is incorporated herein by reference.

B. **DAVIS-BACON ACT, AS AMENDED (40 U.S.C. § 3141-3148).** When required by federal program legislation, all prime construction contracts in excess of \$2,000 awarded by non-federal entities must include a provision for compliance with the Davis-Bacon Act (40 U.S.C. § 3141-3144, and 3146-3148) as supplemented by Department of Labor regulations (29 C.F.R. § 5, “Labor Standards Provisions Applicable to Contracts Covering Federally Financed and Assisted Construction”). In accordance with the statute, contractors must be required to pay wages to laborers and mechanics at a rate not less than the prevailing wages specified in a wage determination made by the Secretary of Labor. In addition, contractors must be required to pay wages not less than once a week. The non-federal entity must place a copy of the current prevailing wage determination issued by the Department of Labor in each solicitation. The decision to award a contract or subcontract must be conditioned upon the acceptance of the wage determination. The non-federal entity must report all suspected or reported violations to the federal awarding agency. The contracts must also include a provision for compliance with the Copeland “Anti-Kickback” Act (40 U.S.C. § 3145), as supplemented by Department of Labor regulations (29 C.F.R. § 3, “Contractors and Subcontractors on Public Building or Public Work Financed in Whole or in Part by Loans or Grants from the United States”). The Act provides that each contractor or subrecipient must be prohibited from inducing, by any means, any person employed in the construction, completion, or repair of public work, to give up any part of the compensation to which he or she is otherwise entitled. The non-federal entity must report all suspected or reported violations to the federal awarding agency. Supplier must be in compliance with all applicable Davis-Bacon Act provisions.

C. CONTRACT WORK HOURS AND SAFETY STANDARDS ACT (40 U.S.C. § 3701-3708). Where applicable, all contracts awarded by the non-federal entity in excess of \$100,000 that involve the employment of mechanics or laborers must include a provision for compliance with 40 U.S.C. §§ 3702 and 3704, as supplemented by Department of Labor regulations (29 C.F.R. § 5). Under 40 U.S.C. § 3702 of the Act, each contractor must be required to compute the wages of every mechanic and laborer on the basis of a standard work week of 40 hours. Work in excess of the standard work week is permissible provided that the worker is compensated at a rate of not less than one and a half times the basic rate of pay for all hours worked in excess of 40 hours in the work week. The requirements of 40 U.S.C. § 3704 are applicable to construction work and provide that no laborer or mechanic must be required to work in surroundings or under working conditions which are unsanitary, hazardous or dangerous. These requirements do not apply to the purchases of supplies or materials or articles ordinarily available on the open market, or contracts for transportation or transmission of intelligence. This provision is hereby incorporated by reference into this Contract. Supplier certifies that during the term of an award for all contracts by Sourcewell resulting from this procurement process, Supplier must comply with applicable requirements as referenced above.

D. RIGHTS TO INVENTIONS MADE UNDER A CONTRACT OR AGREEMENT. If the federal award meets the definition of “funding agreement” under 37 C.F.R. § 401.2(a) and the recipient or subrecipient wishes to enter into a contract with a small business firm or nonprofit organization regarding the substitution of parties, assignment or performance of experimental, developmental, or research work under that “funding agreement,” the recipient or subrecipient must comply with the requirements of 37 C.F.R. § 401, “Rights to Inventions Made by Nonprofit Organizations and Small Business Firms Under Government Grants, Contracts and Cooperative Agreements,” and any implementing regulations issued by the awarding agency. Supplier certifies that during the term of an award for all contracts by Sourcewell resulting from this procurement process, Supplier must comply with applicable requirements as referenced above.

E. CLEAN AIR ACT (42 U.S.C. § 7401-7671Q.) AND THE FEDERAL WATER POLLUTION CONTROL ACT (33 U.S.C. § 1251-1387). Contracts and subgrants of amounts in excess of \$150,000 require the non-federal award to agree to comply with all applicable standards, orders or regulations issued pursuant to the Clean Air Act (42 U.S.C. § 7401- 7671q) and the Federal Water Pollution Control Act as amended (33 U.S.C. § 1251- 1387). Violations must be reported to the Federal awarding agency and the Regional Office of the Environmental Protection Agency (EPA). Supplier certifies that during the term of this Contract will comply with applicable requirements as referenced above.

F. DEBARMENT AND SUSPENSION (EXECUTIVE ORDERS 12549 AND 12689). A contract award (see 2 C.F.R. § 180.220) must not be made to parties listed on the government wide exclusions in the System for Award Management (SAM), in accordance with the OMB guidelines at 2 C.F.R. §180 that implement Executive Orders 12549 (3 C.F.R. § 1986 Comp., p. 189) and 12689 (3 C.F.R. § 1989 Comp., p. 235), “Debarment and Suspension.” SAM Exclusions contains the names

of parties debarred, suspended, or otherwise excluded by agencies, as well as parties declared ineligible under statutory or regulatory authority other than Executive Order 12549. Supplier certifies that neither it nor its principals are presently debarred, suspended, proposed for debarment, declared ineligible, or voluntarily excluded from participation by any federal department or agency.

G. BYRD ANTI-LOBBYING AMENDMENT, AS AMENDED (31 U.S.C. § 1352). Suppliers must file any required certifications. Suppliers must not have used federal appropriated funds to pay any person or organization for influencing or attempting to influence an officer or employee of any agency, a member of Congress, officer or employee of Congress, or an employee of a member of Congress in connection with obtaining any federal contract, grant, or any other award covered by 31 U.S.C. § 1352. Suppliers must disclose any lobbying with non-federal funds that takes place in connection with obtaining any federal award. Such disclosures are forwarded from tier to tier up to the non-federal award. Suppliers must file all certifications and disclosures required by, and otherwise comply with, the Byrd Anti-Lobbying Amendment (31 U.S.C. § 1352).

H. RECORD RETENTION REQUIREMENTS. To the extent applicable, Supplier must comply with the record retention requirements detailed in 2 C.F.R. § 200.333. The Supplier further certifies that it will retain all records as required by 2 C.F.R. § 200.333 for a period of 3 years after grantees or subgrantees submit final expenditure reports or quarterly or annual financial reports, as applicable, and all other pending matters are closed.

I. ENERGY POLICY AND CONSERVATION ACT COMPLIANCE. To the extent applicable, Supplier must comply with the mandatory standards and policies relating to energy efficiency which are contained in the state energy conservation plan issued in compliance with the Energy Policy and Conservation Act.

J. BUY AMERICAN PROVISIONS COMPLIANCE. To the extent applicable, Supplier must comply with all applicable provisions of the Buy American Act. Purchases made in accordance with the Buy American Act must follow the applicable procurement rules calling for free and open competition.

K. ACCESS TO RECORDS (2 C.F.R. § 200.336). Supplier agrees that duly authorized representatives of a federal agency must have access to any books, documents, papers and records of Supplier that are directly pertinent to Supplier's discharge of its obligations under this Contract for the purpose of making audits, examinations, excerpts, and transcriptions. The right also includes timely and reasonable access to Supplier's personnel for the purpose of interview and discussion relating to such documents.

L. PROCUREMENT OF RECOVERED MATERIALS (2 C.F.R. § 200.322). A non-federal entity that is a state agency or agency of a political subdivision of a state and its contractors must comply with Section 6002 of the Solid Waste Disposal Act, as amended by the Resource Conservation

and Recovery Act. The requirements of Section 6002 include procuring only items designated in guidelines of the Environmental Protection Agency (EPA) at 40 C.F.R. § 247 that contain the highest percentage of recovered materials practicable, consistent with maintaining a satisfactory level of competition, where the purchase price of the item exceeds \$10,000 or the value of the quantity acquired during the preceding fiscal year exceeded \$10,000; procuring solid waste management services in a manner that maximizes energy and resource recovery; and establishing an affirmative procurement program for procurement of recovered materials identified in the EPA guidelines.

M. FEDERAL SEAL(S), LOGOS, AND FLAGS. The Supplier not use the seal(s), logos, crests, or reproductions of flags or likenesses of Federal agency officials without specific pre-approval.

N. NO OBLIGATION BY FEDERAL GOVERNMENT. The U.S. federal government is not a party to this Contract or any purchase by an Participating Entity and is not subject to any obligations or liabilities to the Participating Entity, Supplier, or any other party pertaining to any matter resulting from the Contract or any purchase by an authorized user.

O. PROGRAM FRAUD AND FALSE OR FRAUDULENT STATEMENTS OR RELATED ACTS. The Contractor acknowledges that 31 U.S.C. 38 (Administrative Remedies for False Claims and Statements) applies to the Supplier's actions pertaining to this Contract or any purchase by a Participating Entity.

P. FEDERAL DEBT. The Supplier certifies that it is non-delinquent in its repayment of any federal debt. Examples of relevant debt include delinquent payroll and other taxes, audit disallowance, and benefit overpayments.

Q. CONFLICTS OF INTEREST. The Supplier must notify the U.S. Office of General Services, Sourcewell, and Participating Entity as soon as possible if this Contract or any aspect related to the anticipated work under this Contract raises an actual or potential conflict of interest (as described in 2 C.F.R. Part 200). The Supplier must explain the actual or potential conflict in writing in sufficient detail so that the U.S. Office of General Services, Sourcewell, and Participating Entity are able to assess the actual or potential conflict; and provide any additional information as necessary or requested.

R. U.S. EXECUTIVE ORDER 13224. The Supplier, and its subcontractors, must comply with U.S. Executive Order 13224 and U.S. Laws that prohibit transactions with and provision of resources and support to individuals and organizations associated with terrorism.

S. PROHIBITION ON CERTAIN TELECOMMUNICATIONS AND VIDEO SURVEILLANCE SERVICES OR EQUIPMENT. To the extent applicable, Supplier certifies that during the term of this Contract it will comply with applicable requirements of 2 C.F.R. § 200.216.

T. DOMESTIC PREFERENCES FOR PROCUREMENTS. To the extent applicable, Supplier certifies that during the term of this Contract will comply with applicable requirements of 2 C.F.R. § 200.322.

22. CANCELLATION

Sourcewell or Supplier may cancel this Contract at any time, with or without cause, upon 60 days' written notice to the other party. However, Sourcewell may cancel this Contract immediately upon discovery of a material defect in any certification made in Supplier's Proposal. Cancellation of this Contract does not relieve either party of financial, product, or service obligations incurred or accrued prior to cancellation.

Sourcewell

Elliott Equipment Company

DocuSigned by:
Jeremy Schwartz
By: C0FD2A139D06489...
Jeremy Schwartz
Title: Chief Procurement Officer
Date: 12/20/2021 | 2:06 PM CST

DocuSigned by:
M.J. DuBois
By: C65CBA257A53411...
M.J. DuBois, President, DuCo, LLC
Title: Authorized Contract Administrator
Date: 12/20/2021 | 12:17 PM PST

Approved:

DocuSigned by:
Chad Coquette
By: 7E42B8F817A64CC...
Chad Coquette
Title: Executive Director/CEO
Date: 12/20/2021 | 3:51 PM CST

RFP 110421 - Public Utility Equipment with Related Accessories and Supplies

Vendor Details

Company Name: DuCo, LLC
Address: 1079 Tamiami Trl N
#350
Nokomis, Florida 34275
Contact: MJ DUBOIS
Email: mjdubois@ducollc.com
Phone: 410-924-1004
Fax: 410-924-1004
HST#: 81-1963530

Submission Details

Created On: Friday September 17, 2021 07:34:42
Submitted On: Sunday October 24, 2021 12:37:28
Submitted By: MJ DUBOIS
Email: mjdubois@ducollc.com
Transaction #: 3804c47a-b291-4cef-823a-355b260c6ee1
Submitter's IP Address: 47.205.81.175

Specifications**Table 1: Proposer Identity & Authorized Representatives**

General Instructions (applies to all Tables) Sourcwell prefers a brief but thorough response to each question. Do not merely attach additional documents to your response without also providing a substantive response. Do not leave answers blank; respond "N/A" if the question does not apply to you (preferably with an explanation).

Line Item	Question	Response *
1	Proposer Legal Name (one legal entity only): (In the event of award, will execute the resulting contract as "Supplier")	Elliott Equipment Company EIN: 47-0741258
2	Identify all subsidiary entities of the Proposer whose equipment, products, or services are included in the Proposal.	n/a
3	Identify all applicable assumed names or DBA names of the Proposer or Proposer's subsidiaries in Line 1 or Line 2 above.	n/a
4	Proposer Physical Address:	3514 South 25th Street Omaha, NE 68105
5	Proposer website address (or addresses):	www.elliottequip.com
6	Proposer's Authorized Representative (name, title, address, email address & phone) (The representative must have authority to sign the "Proposer's Assurance of Compliance" on behalf of the Proposer and, in the event of award, will be expected to execute the resulting contract):	M.J. DuBois, President of DuCo, LLC will be acting as both Contract Administrator and Authorized Negotiator for the duration of the proposal period and any subsequent contract award. See attached Authorization Letter. DuCo, LLC 1079 Tamiami Trl N #350 Nokomis, FL 34275 email: mjdubois@ducollc.com Phone: 410-924-1004
7	Proposer's primary contact for this proposal (name, title, address, email address & phone):	M.J. DuBois, Authorized Contract Administrator DuCo, LLC 1079 Tamiami Trl N #350 Nokomis, FL 34275 email: mjdubois@ducollc.com Phone: 410-924-1004
8	Proposer's other contacts for this proposal, if any (name, title, address, email address & phone):	Jim Glazer, President Elliott Equipment Company 3514 South 25th Street Omaha, NE 68105 402-932-9492 jim.glazer@elliottequip.com

Table 2: Company Information and Financial Strength

Line Item	Question	Response *
-----------	----------	------------

9	Provide a brief history of your company, including your company's core values, business philosophy, and industry longevity related to the requested equipment, products or services.	<p>Elliott Equipment Company was founded in 1948 by Richard Elliott. The company has been a leading supplier to users in the utility, governmental, sign and lighting, electrical contractor, mining, and related industries for over 70 years. Elliott products were instrumental in building our nation's electrical grid and interstate highway system and continue that tradition to this day.</p> <p>Elliott's mission is 'Creating the Best Solutions for Lifting and Positioning People and Materials'. This simple phrase says a great deal about Elliott, as follows:</p> <p>Creating – Creativity and innovation have been at the core of Elliott since its inception. Elliott was a pioneer in truck-mounted construction equipment. Over the years, Elliott has engineered products that have helped change the work practices of crews in multiple industries, improving safety and efficiency along the way.</p> <p>The Best Solutions – Elliott takes the time to listen closely to its customers, enabling them to design the best machine for their work. Equally importantly, it takes the time to build it to last. Elliott products have exceptionally long useful lives. This helps retain their value and ensure years of trouble-free ownership. In fact, Elliott is still selling repair parts for units built in the 1970's.</p> <p>For Lifting and Positioning People and Materials– All of Elliott's products are multi-functional, and can perform as an aerial work platform, crane and/or digger derrick. They can be further customized, allowing them to do additional tasks as well. This flexibility increases their utilization and maximizes a crew's productivity. The combination of innovation, solid construction and multi-functionality results in Elliott's ability to deliver a solution to optimize the users work as well as their budget.</p> <p>Elliott's values build upon this mission and reflect who they are and how they approach their business. They are as follows: Safety - It is essential in the workplace and the solutions they provide. Customer Satisfaction - Elliott is dedicated to exceeding their customer's expectations. Culture - They operate with integrity, in a dynamic environment based on trust, teamwork, mutual respect and fun. Sustainability - They are responsible to their team members, customers, and stakeholders, to position their business for long term growth and financial stability.</p> <p>As a family-owned company, Elliott's culture is unique and long-term oriented. Elliott is customer focused and prudently managed. They truly care about the people they serve. These values have led to an outstanding reputation and long-term growth over the years.</p> <p>Current ownership purchased Elliott Equipment Company in 1991. At the time of purchase, Elliott offered only two models, a 50 foot and an 80-foot HiReach aerial. Despite the narrow offering, Elliott had loyal customers in the governmental and utility markets.</p> <p>Ownership has dramatically expanded the product line that started with the base two models of HiReach product. The Company now offers a line of over 33 models of HiReach material handling aerial work platforms that range from 45 to 240 feet in working height with options for a variety of platform sizes, platform accessories, insulation, and material handling.</p> <p>Elliott entered the truck mounted crane industry in 2002, to provide users a supplier that was customer solution focused and willing to customize products for their unique applications. Elliott now offers 32 models ranging from 10 to 50 tons in capacity. Elliott cranes are found in diverse applications from power line construction, to road and rail maintenance to mining support.</p> <p>Elliott recently developed its first digger derricks, for use in transmission construction and storm repair. These machines feature long booms, large lifting capacity, and high torque. Like all Elliott machines, the digger derricks are multi-functional, and are capable of digging, lifting loads and positioning people.</p> <p>Product development and innovation are only one part of the company's growth. Ownership has invested significant amounts in plant, equipment, systems, and support to allow Elliott to produce its products consistently, efficiently and with the highest quality. In 2020, Elliott relocated its entire operation to a modern, 210,000 sq/ft production facility in Omaha, NE. The facility is designed to optimize product flow, allowing Elliott the ability to significantly increase its manufacturing capacity and efficiency.</p> <p>When owners purchased the company, Elliott had a total of two factory salesmen, who represented the company directly to the end-users. Elliott now has a sales, service and rental network throughout the U.S. and Canada. Elliott has recently begun establishing a specialized network of distributors to focus specifically on governmental users. These dealers typically sell products like street sweepers, vacuum trucks, and the like. Elliott's products are highly complementary to these lines. By establishing this network Elliott will gain significant exposure to these markets and should allow accelerated growth in the years to come.</p> <p>Elliott will soon celebrate its 75th anniversary. Not only is Elliott one of the very few firms to survive to this milestone, because of its customer and employee focused mission and values, the Company is growing and thriving with its best years still to come.</p>
10	What are your company's expectations in the event of an award?	<p>Elliott is excited about the possibility of another awarded Sourcewell Contract. They have an expectation that a contract awarded will allow your Members to have continued access to innovative, exceptionally built, customizable, multi-function product solutions to their public works, material handling and utility needs.</p> <p>An award will also allow Elliott to participate in reinforcing their goals of superior sales and service support by offering a tool for their distributors to utilize in expanding their market reach. Elliott feels very strongly about their participation in this contract and has actively pursued and signed distributors that are "government houses" that specialize in sales to municipal customers in the last 18 months. These specialized dealers have been actively promoting Elliott's equipment and current Sourcewell Contract extensively throughout the US and Canada.</p> <p>Elliott has experienced a growth in municipal sales due to the Sourcewell Contract and firmly expects that trend to continue.</p>

11	Demonstrate your financial strength and stability with meaningful data. This could include such items as financial statements, SEC filings, credit and bond ratings, letters of credit, and detailed reference letters. Upload supporting documents (as applicable) in the document upload section of your response.	Elliott is a financially strong company. Please see the attached Great Western Bank Reference Letter, and State of Nebraska Certificate of Good Standing.	*
12	What is your US market share for the solutions that you are proposing?	Elliott's HiReach products are very unique, and have few direct competitors. They are not 'bucket trucks' as they offer material handling and platform tools that bucket trucks do not offer. Elliott estimates an 80% market share for those models. Elliott has approximately 20% market share in cranes under 18 tons, which is a primary size for Sourcewell customers. They also have a 40% market share in transmission digger derricks.	*
13	What is your Canadian market share for the solutions that you are proposing?	Elliott estimates that their Canadian market share mirrors their US market share.	*
14	Has your business ever petitioned for bankruptcy protection? If so, explain in detail.	Elliott has never petitioned for bankruptcy.	*
15	How is your organization best described: is it a manufacturer, a distributor/dealer/reseller, or a service provider? Answer whichever question (either a) or b) just below) best applies to your organization. a) If your company is best described as a distributor/dealer/reseller (or similar entity), provide your written authorization to act as a distributor/dealer/reseller for the manufacturer of the products proposed in this RFP. If applicable, is your dealer network independent or company owned? b) If your company is best described as a manufacturer or service provider, describe your relationship with your sales and service force and with your dealer network in delivering the products and services proposed in this RFP. Are these individuals your employees, or the employees of a third party?	b) Elliott Equipment is a manufacturer, located in Omaha Nebraska, which works directly through a North American distribution network. The distributors in North America are individually owned companies. These distributors are assigned a geographic territory for exclusive product representation. Each distributor has sales, service and parts responsibilities within their geographic territory . Elliott also employs "in house" sales, service and parts personnel that support their distributors.	*
16	If applicable, provide a detailed explanation outlining the licenses and certifications that are both required to be held, and actually held, by your organization (including third parties and subcontractors that you use) in pursuit of the business contemplated by this RFP.	See attached Nebraska Motor Vehicle Dealer License. Elliott HiReach aerial work-platforms are designed and built in accordance with ANSI A92.2 standards. Elliott BoomTruck cranes are designed and built in accordance with ASME B30.5 Standards. Elliott Boom Trucks with personnel handling are designed and built in accordance with ASME B30.23 Standards. Elliott Digger Derricks are designed and built in accordance with ANSI A10.31 Standards. Elliott cranes meet OSHA Standard 1926-1400.	*
17	Provide all "Suspension or Debarment" information that has applied to your organization during the past ten years.	Elliott Equipment has never been suspended or disbarred.	*

Table 3: Industry Recognition & Marketplace Success

Line Item	Question	Response *	
18	Describe any relevant industry awards or recognition that your company has received in the past five years	Elliott is recognized by the National Safety Council as one of the safest workplaces in Nebraska, for over eight years running. Elliott has also been awarded the Nebraska Small Exporter of The Year by the Nebraska Business Development Council. They were recently recognized by Lift and Access as a LLEAP awardee and have been chosen as Construction Equipment Magazine's Top 100 New Products of the Year on multiple occasions.. 10/2021 - Model I211 aerial was awarded first place in the Vehicle-Mounted Aerial Lift Category for their LLEAP Awards (The Leadership in Lifting Equipment and Aerial Platforms - LLEAP. Awards normally recognize innovative equipment, support products and services introduced during the previous 12 months. Elliott Equipment hosted the American Welding Society for their annual awards meeting. Nebraska's Governor, Pete Ricketts visited Elliott October 1, 2021 to proclaim National Manufacturing Month.	*
19	What percentage of your sales are to the governmental sector in the past three years	Approximately 10% of Elliott's sales over the past three years have gone to governmental users. Of that 10%, the primary users include municipalities, utilities, toll roads and DOT's, school districts, universities, airports and light rail. Elliott envisions this percentage to increase over time, as they have added dedicated governmental distributors to their distribution team.	*
20	What percentage of your sales are to the education sector in the past three years	Less than 1% of Elliott's sales have been to the education sector.	*
21	List any state, provincial, or cooperative purchasing contracts that you hold. What is the annual sales volume for each of these contracts over the past three years?	Sourcewell is the only cooperative purchasing contract Elliott currently holds.	*
22	List any GSA contracts or Standing Offers and Supply Arrangements (SOSA) that you hold. What is the annual sales volume for each of these contracts over the past three years?	While many Federal agencies (DOE, DOD and NASA) use their products, Elliott does not currently have a GSA contract.	*

Table 4: References/Testimonials

Line Item 23. Supply reference information from three customers who are eligible to be Sourcewell participating entities.

Entity Name *	Contact Name *	Phone Number *	
City of Huntington Beach 200 Main Street Huntington Beach, CA 92648	Cody Jahn, Fleet Operations Supervisor	714-536-5431	*
South Dakota DOT 700 E. Broaway Ave Pierre, SD 57501-2586	Tyler Green, Equipment Manager	605-280-9513 Tyler.green@state.sd.us	*
Metropolitan Airports Commission 6040 28th Ave S Minneapolis, MN 55450	Wayne Steele, Fleet Manager	612-467-0633 wayne.steele@mspmac.org	*

Table 5: Top Five Government or Education Customers

Line Item 24. Provide a list of your top five government, education, or non-profit customers (entity name is optional), including entity type, the state or province the entity is located in, scope of the project(s), size of transaction(s), and dollar volumes from the past three years.

Entity Name	Entity Type *	State / Province *	Scope of Work *	Size of Transactions *	Dollar Volume Past Three Years *	
New Jersey Transit Department	Government	New Jersey - NJ	HiReach Platforms	3 units	\$1,275,836.0	*
Orange County Water District	Government	California - CA	Boom Trucks	2 units	\$850,568.00	*
South Dakota DOT	Government	South Dakota - SD	80' HiReach Platforms	2 units	\$473,553.00	*
Las Vegas Valley Water District	Government	Nevada - NV	Boom Trucks and HiReach Platform	2 units	\$431,330.00	*
Maryland Port Administration	Government	Maryland - MD	110' HiReach Platform	2 units	\$368,596.00	*

Table 6: Ability to Sell and Deliver Service

Describe your company's capability to meet the needs of Sourcwell participating entities across the US and Canada, as applicable. Your response should address in detail at least the following areas: locations of your network of sales and service providers, the number of workers (full-time equivalents) involved in each sector, whether these workers are your direct employees (or employees of a third party), and any overlap between the sales and service functions.

Line Item	Question	Response *
25	Sales force.	Elliott's sales team is comprised of two inside sales managers and three regional sales managers. They work with the distributors and end users in a consultative approach, to ensure they have the optimal machine to do their job.
26	Dealer network or other distribution methods.	Elliott's products are sold, serviced and rented through a network of authorized distributors throughout the United States and Canada. Since the start of their relationship with Sourcwell, they have added a number of the leading distributors of governmental products in the United States to their network. Their pipeline of potential Sourcwell sales has never been larger. See the attached list of exclusive Elliott Equipment distributors.
27	Service force.	Elliott's service team includes five technical support representatives and a four person parts team supporting our nationwide distributor network. They also maintain a supplemental service network in addition to their distributors to minimize any user downtime.
28	Describe the ordering process. If orders will be handled by distributors, dealers or others, explain the respective roles of the Proposer and others.	<p>Sourcwell Members will work directly with their Elliott Distributor on a contract sale.</p> <ol style="list-style-type: none"> 1. When the Member decides to purchase a new Elliott unit, the member will contact their local Elliott distributor. 2. The Member will request a Sourcwell quote from their Distributor and provide their Member Number. 3. Elliott's internal sales staff will work with the distributor and price out a unit based on the SW price and provide the distributor with a Sourcwell Worksheet (see attached sample). The distributor provides the authorized quote to the Member 4. The distributor will receive the Purchase Order from the Sourcwell Member and when placing the order with Elliott to build the unit, return the Sourcwell Worksheet with the Purchase Order. 5. Elliott's Distributor will invoice, deliver the unit once built and train the unit at the customer facility.
29	Describe in detail the process and procedure of your customer service program, if applicable. Include your response-time capabilities and commitments, as well as any incentives that help your providers meet your stated service goals or promises.	<p>Elliott maintains a dedicated quality and after sales support team to support its customers, dealers and service providers. The goal of Elliott's aftersales support is to keep their customer's machines up and always running, with zero downtime. This starts at the factory, where they have a rigorous quality and product testing system, to ensure each machine works as it should when it leaves. Their local dealers perform an predelivery check to prior to placing the machine in service with the user.</p> <p>Elliott offers the longest warranty in the industry, with one year parts and labor on aerials and digger derricks, two years parts and labor on cranes and a lifetime structural warranty on all products.</p> <p>Elliott measures its warranty as a percentage of sales, its quality in terms of scrap, rework and check out time, and its service and parts response time. Continuous improvement in these areas is expected each year.</p> <p>Elliott maintains a significant spare parts inventory and incentivizes its dealers to do the same. The vast majority of parts orders are filled within 24 hours. Next day parts delivery is available upon request.</p> <p>Elliott's service technicians are available 24-7 to support their dealers and customers. Elliott has recently begun adding Bluetooth technology to its machines to assist in remote electrical and hydraulic system troubleshooting. In addition to its dealer network, Elliott has a supplemental network of service-only providers to enhance customer response time. Elliott regularly reviews its dealer's service capabilities and performance, to ensure they offer the highest levels of support to their customers.</p>
30	Describe your ability and willingness to provide your products and services to Sourcwell participating entities in the United States.	Elliott and their distributors sell and service Elliott products throughout the United States and Canada currently and expects to maintain that path with Sourcwell Members.
31	Describe your ability and willingness to provide your products and services to Sourcwell participating entities in Canada.	Elliott views the US and Canada as a single market (North America). Canadian exports comprise approximately 10% of their annual sales. Elliott has distributors across Canada that sell and support their products, just as we do in the United States. Elliott expects to maintain their superior level of sales and service within all areas in Canada.
32	Identify any geographic areas of the United States or Canada that you will NOT be fully serving through the proposed contract.	Sourcwell is Elliott's sole cooperative purchasing contract. Elliott will have no restrictions on their contract sales and support anywhere in North America.
33	Identify any Sourcwell participating entity sectors (i.e., government, education, not-for-profit) that you will NOT be fully serving through the proposed contract. Explain in detail. For example, does your company have only a regional presence, or do other cooperative purchasing contracts limit your ability to promote another contract?	Elliott wishes to sell to and support all Sourcwell Members and sees no restrictions for any entity sectors.
34	Define any specific contract requirements or restrictions that would apply to our participating entities in Hawaii and Alaska and in US Territories.	Elliott has no additional requirements or restrictions for Alaska, Hawaii or any US Territory other than time in shipment and the applicable cost of shipping. All items will be disclosed on the quotation prior to a Member issuing a Purchase Order.

Table 7: Marketing Plan

Line Item	Question	Response *
35	Describe your marketing strategy for promoting this contract opportunity. Upload representative samples of your marketing materials (if applicable) in the document upload section of your response.	<p>Elliott believes it is imperative to the success of their anticipated Sourcewell Contract award that the Executive Staff embraces the culture of contract sales. With the support/directive from Elliott Management and a "Go-To-Market" strategy developed, Elliott will continue to educate their sales, service, and distributor network about the award and what it will mean in maximizing municipal sales avenues. Both DuCo LLC (our Contract Administrator) and Sourcewell Supplier Development personnel will help with this process, make sure goals are met, and contract requirements are maintained. Elliott will hold national sales meetings to promote any new award to their internal staff, and distributors. The education of the distributor's sales teams will be accomplished by both one on one meetings and by group sales meetings. Elliott's response to this solicitation has been designed with success in mind; they believe that both the distributor and Sourcewell Member must be accepting of their Pricing for realization of their goals.</p> <p>Elliott will utilize Sourcewell's promotional flags at industry trade shows, Sourcewell Logo's on municipal market specific literature, ads, and web site. See attached examples</p>
36	Describe your use of technology and digital data (e.g., social media, metadata usage) to enhance marketing effectiveness.	<p>Elliott maintains a presence on social media outlets, including LinkedIn, Facebook, Twitter and Instagram. Their goal in doing so is to maintain and grow their user interaction with the Elliott brand by sharing Company and product news, success stories and other industry items of interest. Elliott continues to grow in followers each week.</p> <p>In addition to those items, Elliott has a monthly e-newsletter that it sends to customers and prospects. They also utilize Google Adwords to drive additional traffic to their website.</p>
37	In your view, what is Sourcewell's role in promoting contracts arising out of this RFP? How will you integrate a Sourcewell-awarded contract into your sales process?	<p>Sourcewell has an exceptional reputation and based on their steady increase of sales, knows how to promote their contracts. Elliott believes that Sourcewell's marketing model works. The basis for longevity is service related and from what Elliott's municipal customers are saying, Sourcewell is aware of this concept. Elliott Expects the same existence at trade shows, Getting to Know You and Sourcewell University events will be continued as can be in the new COVID environment.</p> <p>Sourcewell Vendor paraphernalia available to contract holders is also helpful for trade shows and the new Vendor Supplier section of the Website has been and will be utilized.</p>
38	Are your products or services available through an e-procurement ordering process? If so, describe your e-procurement system and how governmental and educational customers have used it.	Elliott's products do not lend themselves to e-procurement ordering; there is no option for it.

Table 8: Value-Added Attributes

Line Item	Question	Response *
39	Describe any product, equipment, maintenance, or operator training programs that you offer to Sourcewell participating entities. Include details, such as whether training is standard or optional, who provides training, and any costs that apply.	In conjunction with their dealers, Elliott offers a variety of services, including, but not limited to, operator and mechanic training, crane operator certification, periodic inspections and more. Dealer provided operator training is standard. Sourcewell members can work with their dealer or Elliott to design a custom training curriculum. In depth training like this typically costs \$1,800 per day, plus travel.
40	Describe any technological advances that your proposed products or services offer.	During the past three years, Elliott has been on a campaign to update their control systems from direct wiring to a CANbus network. This improves reliability and service times. In addition, their controls have Bluetooth capability, which allows the user to contact the dealer or factory for trouble shooting. The Bluetooth package gives additional operating information and adaptability for the user. This technology is on all of Elliott cranes with cabs, and is making its way through to the HiReach line starting with the V60 and L65 models.

41	Describe any "green" initiatives that relate to your company or to your products or services, and include a list of the certifying agency for each.	<p>Elliott's Green Product Attributes</p> <p>Designed a special manifold to reduce number of hydraulic fittings and leak points.</p> <p>Remote engine start/stop to allow engine shut down to minimize fuel usage and emissions.</p> <p>ANSI A92.2 compliance for aerial work platforms (HiReach, SkyWalk, ELine).</p> <p>ANSI A10.31 compliance for digger derricks.</p> <p>ASME B30.5 compliance for boom trucks/cranes.</p> <p>All products are designed to optimize strength and weight. This allows products to be mounted on lighter chassis to consume less fuel.</p> <p>Products are designed and built to minimize weight while maximizing product life. Lower weight products also minimize impact on roads, prolonging road life.</p> <p>Products are designed to minimize operator fatigue and for safe operator use. Ingress/egress, operator controls, sight-lines and set up/tear down are all factored into design.</p> <p>Safe and Healthy Buildings</p> <p>Eye and ear protection required, hearing testing required, buildings monitored for noise level and air quality.</p> <p>Lean environment where materials and tools are minimized and in their place.</p> <p>New, state of the art ventilation and air filtration for paint, prep and burning operations.</p> <p>Safety scrap and waste are key performance indicators that are measured and worked for continuous improvement. Safety committee, safety meetings, safety recognition.</p> <p>Worker's compensation experience mod of .78, far better than industry average.</p> <p>All lighting in buildings has been retrofit with LED fixtures and motion sensors for better light and lower energy consumption.</p> <p>Waste is properly marked and disposed of. Paper is recycled. Laser or plasma cut steel is computer nested to minimize waste. Steel scrap is recycled. Elliott reclaims cleaning solvents used in paint preparation.</p> <p>On line registration, manuals and parts ordering significantly reduce paper use.</p> <p>Elliott is Efficient in Use of Materials</p> <p>Well-designed structures not only give the machine a longer useful life (reflected in its lifetime structural warranty), but also lengthen chassis life, by minimizing chassis frame twist and maximizing the structure of the chassis. The longer lived products reduce the need for rapid replacement.</p> <p>Multi-functionality allows more work to be done with a single machine which reduces machine count. Minimized piece count of machine to reduce opportunities for rework and scrap.</p> <p>Products are designed to minimize weight / material.</p> <p>Designed to reduce downtime, so fewer hydraulic fittings, fewer electrical connections, designed to maximize user safety and productivity.</p> <p>Rework and scrap are tracked for continuous improvement.</p> <p>Vendors are evaluated for quality and defects to reduce their scrap and rework.</p> <p>Training on floor ensures proper work is done, reducing scrap and rework.</p> <p>Only certified welders are used, to minimize material waste.</p> <p>Units are designed for exceptionally long useful life, and given lifetime structural warranty – this minimizes the need for regular replacement which saves trucks and other resources.</p> <p>Elliott moved to a new energy efficient building in April 2020. The building has excellent natural lighting and LED lights throughout with motion sensors. Green also includes safety and Elliott is consistently recognized by the National Safety Council as one of the safest companies in Nebraska.</p>
42	Identify any third-party issued eco-labels, ratings or certifications that your company has received for the equipment or products included in your Proposal related to energy efficiency or conservation, life-cycle design (cradle-to-cradle), or other green/sustainability factors.	<p>Elliott does not have any third party certifications. It is important to note however, that during their current contract term, they have moved locations to a far more energy efficient building with state of the art air handling, energy efficient lighting, excellent material flow and new electrical systems. In addition, one of the primary considerations in their product designs is weight. They recently redesigned their most popular model and reduced its weight by over 20%. This contributes to increased fuel economy and lower ownership costs for Elliott users.</p>
43	Describe any Women or Minority Business Entity (WMBE), Small Business Entity (SBE), or veteran owned business certifications that your company or hub partners have obtained. Upload documentation of certification (as applicable) in the document upload section of your response.	<p>A number of Elliott's local distributors are SBE, MBE, WMBE or Veteran owned businesses. The actual participation of each will be dictated by the customer's delivery area. The actual percentage of SBE, MBE, WMBE or Veteran owned business information can be provided to the customer upon request prior to the order being placed.</p> <p>Elliott is also utilizing a Small Woman Owned Business, DuCo, LLC, to administer the proposed Sourcewell Contract.</p>

44	<p>What unique attributes does your company, your products, or your services offer to Sourcewell participating entities? What makes your proposed solutions unique in your industry as it applies to Sourcewell participating entities?</p>	<p>Only Elliott HiReach aeriels have the platform size and accessories of self-propelled aerial combined with platform material handling and main boom lifting capabilities. This allows crews to use one machine to do the work of two, increasing utilization and reducing equipment costs.</p> <p>All Elliott aeriels are telescopic. Their 'point and shoot' design allows greater side reach to minimize lane closures and eliminates tail swing, protecting workers from accidentally moving a portion of the boom into traffic. Like a Swiss Army Knife, HiReach aeriels let workers do more jobs with a single piece of equipment.</p> <p>Elliott cranes are unique in that they can mount on lighter chassis, which differentiates them in water and sewer related activities. Only Elliott cranes have the capability to power hydraulic tools like clam buckets or grapples at the boom tip, eliminating the need to drag a hydraulic line on the ground. Elliott cranes can be equipped with remote control work platforms or post hole augers for even more savings to Sourcewell members.</p> <p>Elliott's digger derricks have taller tip heights, greater lifting capacity, and higher digging torque than any other machines on the market. They also can mount on a tandem axle chassis, with no permits required.</p> <p>Currently Elliott has several design initiatives in progress which will benefit Sourcewell members. One of these is reducing the weight of the Company's aerial work platforms, so they use less material and can fit on smaller trucks (or offer more carrying capacity on larger trucks) minimizing the need for a CDL and maximizing fuel economy.</p> <p>Examples of this include their new L65, which replaces one of their most popular units, the L60, and offers more reach, better lifting and weighs 3,000 lbs. less. The new M87, 87-foot aerial fits on a non-CDL chassis and offers more reach and lifting capacity on this class of chassis than anyone in the world. Elliott's new digger derricks also can mount on tandem axle chassis with no pusher or tag axle needed.</p> <p>Elliott is also transitioning to a next generation control system for its products, that allows for operators to individualize the performance of their machines and perform diagnostic system checks using Bluetooth technology.</p> <p>A third initiative is to allow users to maximize the utilization of their investment. As an example, Elliott's new E150 transmission machine is the industry's first machine to feature interchangeable booms and platforms, material handling and over-center boom operation. This single machine can do the work of five, literally cutting the cost of operation by over 50%, while simultaneously improving machine utilization and worker efficiency.</p>
----	---	---

Table 9: Warranty

Describe in detail your manufacturer warranty program, including conditions and requirements to qualify, claims procedure, and overall structure. You may upload representative samples of your warranty materials (if applicable) in the document upload section of your response in addition to responding to the questions below.

Line Item	Question	Response *
45	Do your warranties cover all products, parts, and labor?	<p>Elliott's warranties cover parts and labor for one year (two years for cranes). Elliott is the only company in the industry to offer a lifetime structural warranty on all of their products.</p> <p>Customers can purchase extended parts and labor warranties if desired.</p>
46	Do your warranties impose usage restrictions or other limitations that adversely affect coverage?	No usage restrictions are imposed on the warranty. The only limitations apply if equipment has been misused, modified, not maintained, operator error or third party (non-Elliott) replacement parts have been used.
47	Do your warranties cover the expense of technicians' travel time and mileage to perform warranty repairs?	Elliott's warranty covers technician travel time and mileage. This work is typically performed by the distributor closest to the user.
48	Are there any geographic regions of the United States or Canada (as applicable) for which you cannot provide a certified technician to perform warranty repairs? How will Sourcewell participating entities in these regions be provided service for warranty repair?	Elliott does not expect any region not to be covered by their distributors. Elliott has distributors and service providers coast to coast. Most of these have physical shops as well as the ability to provide field service and warranty repair.
49	Will you cover warranty service for items made by other manufacturers that are part of your proposal, or are these warranties issues typically passed on to the original equipment manufacturer?	Elliott's warranty covers all Elliott supplied items. Chassis are covered under their respective manufacturer's warranties. In cases of other significant third party parts that are added to the machine (like a welder/generator or rail gear), or provided by the user, the warranty would be a pass through from their respective manufacturer.
50	What are your proposed exchange and return programs and policies?	Elliott manufactures specialized equipment, built to suit, and does not offer exchanges or returns.
51	Describe any service contract options for the items included in your proposal.	<p>The purchasing Member can contact the local distributor for any service contracts. This is not something that can be purchased at the factory level.</p> <p>Customers can choose to purchase extended warranties of up to five years for their unit and/or truck chassis at the time of new unit purchase.</p>

Table 10: Payment Terms and Financing Options

Line Item	Question	Response *
52	Describe your payment terms and accepted payment methods?	Payment terms are net 30 days unless otherwise arranged prior to purchase on a case-by-case basis. Payments or units can be made by check, wire transfer or Automated Clearing House transfer (ACH).
53	Describe any leasing or financing options available for use by educational or governmental entities.	Elliott will offer municipal and non-profit leasing through third party vendors if there is Member interest. Elliott does not quote rates or terms for leasing, however it should be known to Members that we have this service available to them. Elliott will work with other Sourcewell Awarded Vendors (NCL) or any leasing agency of the Member's choice.
54	Describe any standard transaction documents that you propose to use in connection with an awarded contract (order forms, terms and conditions, service level agreements, etc.). Upload a sample of each (as applicable) in the document upload section of your response.	See the attached Sourcewell Distributor Worksheet commonly used with the current Sourcewell Contract. This form will be used with any future award for information to the Distributor and recognition as a Sourcewell Sale.
55	Do you accept the P-card procurement and payment process? If so, is there any additional cost to Sourcewell participating entities for using this process?	P-card procurement is not accepted.

Table 11: Pricing and Delivery

Provide detailed pricing information in the questions that follow below. Keep in mind that reasonable price and product adjustments can be made during the term of an awarded Contract as described in the RFP, the template Contract, and the Sourcewell Price and Product Change Request Form.

Line Item	Question	Response *
56	Describe your pricing model (e.g., line-item discounts or product-category discounts). Provide detailed pricing data (including standard or list pricing and the Sourcewell discounted price) on all of the items that you want Sourcewell to consider as part of your RFP response. If applicable, provide a SKU for each item in your proposal. Upload your pricing materials (if applicable) in the document upload section of your response.	It is Elliott's intent to offer a percentage discount from the manufacturer list price to the Sourcewell Members on all of the items being proposed in this offer. Elliott's discount will be based on a percentage off of the base model and price listed options.
57	Quantify the pricing discount represented by the pricing proposal in this response. For example, if the pricing in your response represents a percentage discount from MSRP or list, state the percentage or percentage range.	Elliott is offering a discount of 7% on HiReach and Digger Derricks and a 6% discount on Boom Truck Cranes. This discount will be for the Elliott Base Unit and Elliott Price Listed options. Chassis will not be discounted.
58	Describe any quantity or volume discounts or rebate programs that you offer.	Elliott will offer additional discounts for volume purchases. There will be an additional 2% discount off the base unit discounted price for a single Purchase Order for 4 or more units. At this time, Elliott does not offer any rebate programs.
59	Propose a method of facilitating "sourced" products or related services, which may be referred to as "open market" items or "nonstandard options". For example, you may supply such items "at cost" or "at cost plus a percentage," or you may supply a quote for each such request.	It is Elliott's intention to cover all items available on their commercial price lists. Elliott does realize, from time to time, there may be individual requirements that will not be listed. Elliott will provide any items "specific" to Sourcewell Members needs that they are able to. The pricing for such items will be cost plus 20%. Prior to accepting an order with Open Market items from a Sourcewell Member, Elliott will discuss the availability of a specific request and price the item. Any documentation of cost that Elliott can provide for these items will be presented on an individual basis when requested. In cases where there is additional engineering and integration required, Elliott will provide this cost information to the customer at the time of their quote.

60	Identify any element of the total cost of acquisition that is NOT included in the pricing submitted with your response. This includes all additional charges associated with a purchase that are not directly identified as freight or shipping charges. For example, list costs for items like pre-delivery inspection, installation, set up, mandatory training, or initial inspection. Identify any parties that impose such costs and their relationship to the Proposer.	<p>There are several costs not included in the pricing submitted in this proposal. These costs are listed below:</p> <p>Freight and Delivery: Freight costs will be pre-paid and added to the Members Quote and Invoice. Small items will be, in most cases, delivered by UPS. Other freight carriers may be utilized in shipments, i.e. Federal Express, DHL drive-away service, and common carrier. The actual cost of shipment will be passed through to the customer. Elliott will not mark up this item for profit. Minimal handling fees may be added where special packaging is required. The Member will be notified of these charges if applicable prior to order placement.</p> <p>Federal Excise Tax: Elliott is required by law to collect Federal Excise Tax on any truck mounted unit rated above 33,000 GVW. This tax will be added to the customer invoice as a separate line item. Elliott will pay this tax directly to the Internal Revenue Service. The rate of tax is calculated at 12%. Most municipal and non-profit entities are exempt from this tax. If Elliott is provided a Federal Excise Tax Exemption Certificate, they will not be required to collect this tax.</p> <p>Mounting Fee: This fee is charged to the customer when ordering a truck mounted unit. Mounting fees cover the cost of the mounting of the body on the desired truck chassis.</p> <p>Federally Mandated Items: The cost of any federally mandated items will be passed on to the Member. Elliott pricing includes any federally mandated items that are mandated at the time of this proposal. Should there be a Federal Mandate after the date of this proposal, any cost incurred to meet the requirements of this mandate will be passed on to the member. Any costs applicable will be provided to the Member prior to any Purchase Order being issued. This fee would typically be charged to meet any future EPA standards that may arise. An example of such costs would be in meeting Federal Emission Standards.</p> <p>Local Dealer Pre-Delivery Inspection, On Site Training, and Local Delivery Fees: These costs are charged by local dealers to inspect, test, in service the unit, local extended delivery and follow up training. These costs are a pass through cost to the member from the local dealer.</p>
61	If freight, delivery, or shipping is an additional cost to the Sourcewell participating entity, describe in detail the complete freight, shipping, and delivery program.	<p>All freight charges are pre-paid and added to the Member quotation for convenience. Members always have the choice of picking up the units at the factory or retaining a 3rd party of their choice to deliver the equipment. The freight charges are at a pass-through price. Elliott has negotiated quantity-discounted shipping rates and will pass those discounts on to the Members.</p> <p>Most offered items are custom built to customer specification. Anticipated delivery of items ordered on a stock chassis or customer supplied chassis is expected to be 45-90 days after receipt of order or customer chassis. Anticipated delivery of an item ordered on a "special order" chassis is expected to be 120-180 days after receipt of order; however, this time can vary greatly depending upon chassis manufacturer back log.</p> <p>Delivery of truck mounted units will be pre-paid and added to Member Quotation and Invoice. Both "Drive-A-Way" service and common carrier service will be used.</p>
62	Specifically describe freight, shipping, and delivery terms or programs available for Alaska, Hawaii, Canada, or any offshore delivery.	<p>The shipping and delivery charges for Canada, Alaska and Hawaii and any other off shore location are the same as the previously stated delivery programs for the contiguous US. The shipping charges to the port location will be calculated in the same manner.</p> <p>If the customer wishes that Elliott deliver via ocean transport, Elliott will pass on the negotiated shipping rates that they will pay to the ocean transport carrier to the Member. It has been their experience that the customers in these locations usually have their own negotiated rates with shipping carriers. If this is the case, Elliott will provide the customer shipping to their desired port and provide the customer with the appropriate documentation required. Elliott strives to provide the equipment as customer specified and to their satisfaction upon delivery.</p>
63	Describe any unique distribution and/or delivery methods or options offered in your proposal.	<p>As stated above, Elliott passes on negotiated bid freight pricing to their customers.</p> <p>Most of the Elliott distributors have units in stock and Member's can purchase those units to enhance delivery times and in some cases better prices.</p>

Table 12: Pricing Offered

Line Item	The Pricing Offered in this Proposal is: *	Comments
64	c. better than the Proposer typically offers to GPOs, cooperative procurement organizations, or state purchasing departments.	Elliott gives the best discounts available to Sourcewell Members.

Table 13: Audit and Administrative Fee

Line Item	Question	Response *
65	Specifically describe any self-audit process or program that you plan to employ to verify compliance with your proposed Contract with Sourcewell. This process includes ensuring that Sourcewell participating entities obtain the proper pricing, that the Vendor reports all sales under the Contract each quarter, and that the Vendor remits the proper administrative fee to Sourcewell. Provide sufficient detail to support your ability to report quarterly sales to Sourcewell as described in the Contract template.	Elliott closely monitors their distributor's Sourcewell opportunities and sales. Typically, Elliott's distributors request pricing from Elliott for each machine they are selling. This is because Elliott's products are all customizable, and governmental customers tailor their equipment to best fit their applications. As an additional tracking mechanism, Elliott reviews their warranty registrations and contacts all of their customers when they register a unit, this is done for customer satisfaction, distributor satisfaction and when municipal customers are involved, to verify what vehicle they used to purchase their unit.
66	If you are awarded a contract, provide a few examples of internal metrics that will be tracked to measure whether you are having success with the contract.	Elliott establishes annual objectives with their distributors and reviews their progress throughout the year. Items they specifically track include sales calls, quotations, quotations converted to orders, and total sales under the Sourcewell contract. Elliott then discusses the dealer's progress on these and develops an ongoing plan to improve their performance.
67	Identify a proposed administrative fee that you will pay to Sourcewell for facilitating, managing, and promoting the Sourcewell Contract in the event that you are awarded a Contract. This fee is typically calculated as a percentage of Vendor's sales under the Contract or as a per-unit fee; it is not a line-item addition to the Member's cost of goods. (See the RFP and template Contract for additional details.)	Elliott proposes an administrative fee of 1%. The fee will be calculated on the Member price.

Table 14A: Depth and Breadth of Offered Equipment Products and Services

Line Item	Question	Response *
68	Provide a detailed description of the equipment, products, and services that you are offering in your proposal.	<p>HiReach – HiReach Truck-Mounted Material Handling Aerial Work Platforms</p> <p>Elliott HiReach material handling aerial work platforms feature a heavy duty, telescopic boom design, with easy 'point and shoot' operation. Material handling is available for all HiReach products, commonly both on the main boom and in work platform. This allows the machines to multi-function, increasing their versatility and lowering operating costs by eliminating the need for two separate units and chassis.</p> <p>Elliott's HiReach product line offers working heights from 48-240 feet. They offer 19 models within this range, all of which can be customized to optimize them for the user's application. This wide variety of models allows users to reach further and gives flexibility in choosing the optimal height for their application.</p> <p>The telescopic nature of Elliott's machines eliminates tail-swing inherent in an articulated boom. This simplifies operation and eliminates the risk of inadvertently swinging the 'knuckle' of the boom into traffic. The telescopic design also maximizes side reach, allowing users to reach further in a single set up.</p> <p>The HiReach work platform is unique in that it has an open rail design and is typically sized at 40"x60" or larger (up to 16 feet long). The standard 40"x60" platform allows for more than double the work surface of a typical 24"x48" two-worker fiberglass bucket. In addition, the open rail of the HiReach platform allows for far greater range of access for workers than enclosed bucket. Also offered, enclosed fiberglass buckets upon request; however users almost always opt for the platform design.</p> <p>Only Elliott offers "Office in the Sky" platform accessories include 110V, hydraulic tools, air tools, pressure washer, welder, oxy/acetylene, material handling forks and material handling jib winch. This is the largest range of platform tools of any truck mounted aerial device and allows users to maximize the types of work they do while in the air.</p> <p>Elliott HiReach units can also handle materials from both the main boom and the work platform. Typically the units offer 5,900 lbs. capacity from the main boom and 500 lbs. from the platform. Insulated units offer 3,650 lbs. material handling and longer units offer up to 15,000 lbs. material handling. This adds additional functionality and allows one machine to do the work of two or more.</p> <p>Users can also add an optional post hole digger to three and four section units (50-90 feet models), to provide a third major application to their machine.</p> <p>Elliott will further customize their units for fit a unique application. For example, they offer special outriggers that allow users to clear guardrails and get extra vertical penetration for the shoulder. Special bodies, lighting, tool circuits, recovery winches and other equipment are also available.</p> <p>All Elliott HiReach units are certified to ANSI A92.2 in personnel, material handling, and digging modes. This ensures outstanding stability and structural integrity.</p> <p>Elliott HiReach units feature a full-length sub-frame and oversize turret and bearing. This allows Elliott to back them with a lifetime structural warranty.</p> <p>Finally, Elliott works with all chassis manufacturers and can either supply a chassis or the user can supply their own if desired.</p> <p>Digger Derricks Elliott has a growing line of digger derricks. Currently there are three models, with 86-, 105- and 115-foot tip heights, respectively. Elliott digger derricks are designed for use in the most demanding applications - transmission line construction and storm work. They feature the longest boom lengths, highest digging torque, wide digging radius, class leading material handling capacity at digging radius, full hydraulic controls and can mount on standard tandem axle chassis. Elliott is in the process of expanding their digger derrick product line, and plan to add multiple new models in the coming three years.</p> <p>Elliott Digger Derricks are backed by a one-year parts and labor warranty and lifetime structural warranty which is the best in the industry.</p> <p>Boom Truck - Boom Truck Mounted Telescopic Cranes In addition to their HiReach aeriels and digger derricks, Elliott offers 14 models of truck mounted telescoping cranes 'BoomTrucks' that range from 10-50 tons of lifting capacity, boom lengths from 39 to 142 feet, and tip heights up to 207 feet. All of Elliott's BoomTrucks feature a telescopic design for simple 'point and shoot' operation.</p> <p>Elliott offers the widest selection of telescopic truck mounted cranes between 10-18 tons in the industry. These models are tailored for typical Sourcewell member applications, as they are compact, easy to operate and customizable. Users can add several options including hydraulic powered grapples, radio remote controlled work platforms, post hole diggers, lights, bodies and much more.</p> <p>Like all Elliott products, their BoomTrucks use the latest technology from industry leading suppliers to ensure smooth and trouble-free operation. All Elliott Boom Trucks comply with ASME B30.5 and ASME B30.23 for mobile and locomotive cranes.</p> <p>Elliott Boom Trucks are backed by a two-year parts and labor warranty and lifetime structural warranty which is the best in the industry.</p>
69	Within this RFP category there may be subcategories of solutions. List subcategory titles that best describe your products and services.	<p>Truck-mounted multi-function equipment Material handling aerial work platforms Boom Truck cranes Digger Derricks</p>

Table 14B: Depth and Breadth of Offered Equipment Products and Services

Indicate below if the listed types or classes of equipment, products, and services are offered within your proposal. Provide additional comments in the text box provided, as necessary.

Line Item	Category or Type	Offered *	Comments
70	Telescopic, articulated, mast, and boom, aerial lifts, towers, buckets, and platforms	<input checked="" type="radio"/> Yes <input type="radio"/> No	HiReach models and cranes are offered in this category.
71	Digger derricks, and cable placing, pulling, and tensioning equipment	<input checked="" type="radio"/> Yes <input type="radio"/> No	Elliott offers digger derrick models in this response
72	Directional drills, trenchless excavation equipment, thrust and boring machines, soil piercing tools, trenchers, rock wheels, and pile drivers	<input type="radio"/> Yes <input checked="" type="radio"/> No	not offered
73	Utility locating equipment	<input type="radio"/> Yes <input checked="" type="radio"/> No	not offered
74	Accessories, supplies, replacement or wear parts, and services related to the offering of equipment in Lines 69-72	<input type="radio"/> Yes <input checked="" type="radio"/> No	not offered - to offer this kind of item would require more effort to track and report sales than is possible at this time.

Table 15: Exceptions to Terms, Conditions, or Specifications Form

Line Item 75. NOTICE: To identify any exception, or to request any modification, to the Sourcewell template Contract terms, conditions, or specifications, a Proposer must submit the exception or requested modification on the **Exceptions to Terms, Conditions, or Specifications Form** immediately below. The contract section, the specific text addressed by the exception or requested modification, and the proposed modification must be identified in detail. Proposer's exceptions and proposed modifications are subject to review and approval of Sourcewell and will not automatically be included in the contract.

Contract Section	Term, Condition, or Specification	Exception or Proposed Modification

Documents

Ensure your submission document(s) conforms to the following:

- Documents in PDF format are preferred. Documents in Word, Excel, or compatible formats may also be provided.
- Documents should NOT have a security password, as Sourcewell may not be able to open the file. It is your sole responsibility to ensure that the uploaded document(s) are not either defective, corrupted or blank and that the documents can be opened and viewed by Sourcewell.
- Sourcewell may reject any response where any document(s) cannot be opened and viewed by Sourcewell.
- If you need to upload more than one (1) document for a single item, you should combine the documents into one zipped file. If the zipped file contains more than one (1) document, ensure each document is named, in relation to the submission format item responding to. For example, if responding to the Marketing Plan category save the document as "Marketing Plan."
 - [Pricing](#) - 2021 Elliott Sourcewell Price List.zip - Sunday October 24, 2021 12:31:02
 - [Financial Strength and Stability](#) - Elliott Financial Strgth Docs.zip - Sunday October 24, 2021 12:31:42
 - [Marketing Plan/Samples](#) - Elliott Marketing Docs.zip - Sunday October 24, 2021 12:32:28
 - WMBE/MBE/SBE or Related Certificates (optional)
 - [Warranty Information](#) - Elliott Warranty Docs.zip - Sunday October 24, 2021 12:32:44
 - [Standard Transaction Document Samples](#) - SW Worksheet - End User Info.pdf - Sunday October 24, 2021 12:32:58
 - [Upload Additional Document](#) - References.zip - Sunday October 24, 2021 12:33:15

Addenda, Terms and Conditions**PROPOSER AFFIDAVIT AND ASSURANCE OF COMPLIANCE**

I certify that I am the authorized representative of the Proposer submitting the foregoing Proposal with the legal authority to bind the Proposer to this Affidavit and Assurance of Compliance:

1. The Proposer is submitting this Proposal under its full and complete legal name, and the Proposer legally exists in good standing in the jurisdiction of its residence.
2. The Proposer warrants that the information provided in this Proposal is true, correct, and reliable for purposes of evaluation for contract award.
3. The Proposer, including any person assisting with the creation of this Proposal, has arrived at this Proposal independently and the Proposal has been created without colluding with any other person, company, or parties that have or will submit a proposal under this solicitation; and the Proposal has in all respects been created fairly without any fraud or dishonesty. The Proposer has not directly or indirectly entered into any agreement or arrangement with any person or business in an effort to influence any part of this solicitation or operations of a resulting contract; and the Proposer has not taken any action in restraint of free trade or competitiveness in connection with this solicitation. Additionally, if Proposer has worked with a consultant on the Proposal, the consultant (an individual or a company) has not assisted any other entity that has submitted or will submit a proposal for this solicitation.
4. To the best of its knowledge and belief, and except as otherwise disclosed in the Proposal, there are no relevant facts or circumstances which could give rise to an organizational conflict of interest. An organizational conflict of interest exists when a vendor has an unfair competitive advantage or the vendor's objectivity in performing the contract is, or might be, impaired.
5. The contents of the Proposal have not been communicated by the Proposer or its employees or agents to any person not an employee or legally authorized agent of the Proposer and will not be communicated to any such persons prior to Due Date of this solicitation.
6. If awarded a contract, the Proposer will provide to Sourcewell Participating Entities the equipment, products, and services in accordance with the terms, conditions, and scope of a resulting contract.
7. The Proposer possesses, or will possess before delivering any equipment, products, or services, all applicable licenses or certifications necessary to deliver such equipment, products, or services under any resulting contract.
8. The Proposer agrees to deliver equipment, products, and services through valid contracts, purchase orders, or means that are acceptable to Sourcewell Members. Unless otherwise agreed to, the Proposer must provide only new and first-quality products and related services to Sourcewell Members under an awarded Contract.
9. The Proposer will comply with all applicable provisions of federal, state, and local laws, regulations, rules, and orders.
10. The Proposer understands that Sourcewell will reject RFP proposals that are marked "confidential" (or "nonpublic," etc.), either substantially or in their entirety. Under Minnesota Statutes Section 13.591, subdivision 4, all proposals are considered nonpublic data until the evaluation is complete and a Contract is awarded. At that point, proposals become public data. Minnesota Statutes Section 13.37 permits only certain narrowly defined data to be considered a "trade secret," and thus nonpublic data under Minnesota's Data Practices Act.
11. Proposer its employees, agents, and subcontractors are not:
 1. Included on the "Specially Designated Nationals and Blocked Persons" list maintained by the Office of Foreign Assets Control of the United States Department of the Treasury found at: <https://www.treasury.gov/ofac/downloads/sdnlist.pdf>;
 2. Included on the government-wide exclusions lists in the United States System for Award Management found at: <https://sam.gov/SAM/>; or
 3. Presently debarred, suspended, proposed for debarment, declared ineligible, or voluntarily excluded from programs operated by the State of Minnesota; the United States federal government or the Canadian government, as applicable; or any Participating Entity. Vendor certifies and warrants that neither it nor its principals have been convicted of a criminal offense related to the subject matter of this solicitation.

By checking this box I acknowledge that I am bound by the terms of the Proposer's Affidavit, have the legal authority to submit this Proposal on behalf of the Proposer, and that this electronic acknowledgment has the same legal effect, validity, and enforceability as if I had hand signed the Proposal. This signature will not be denied such legal effect, validity, or enforceability solely because an electronic signature or electronic record was used in its formation. - M.J. DuBois, Contract Administrator, DuCo, LLC

The Proposer declares that there is an actual or potential Conflict of Interest relating to the preparation of its submission, and/or the Proposer foresees an actual or potential Conflict of Interest in performing the contractual obligations contemplated in the bid.

Yes No

The Bidder acknowledges and agrees that the addendum/addenda below form part of the Bid Document.

Check the box in the column "I have reviewed this addendum" below to acknowledge each of the addenda.

File Name	I have reviewed the below addendum and attachments (if applicable)	Pages
Addendum_4_Public_Utility_Equipment_RFP_110421 Thu October 14 2021 04:33 PM	<input checked="" type="checkbox"/>	2
Addendum_3_Public_Utility_Equipment_RFP_110421 Mon September 27 2021 05:28 PM	<input checked="" type="checkbox"/>	1
Addendum_2_Public_Utility_Equipment_RFP_110421 Fri September 24 2021 03:55 PM	<input checked="" type="checkbox"/>	1
Addendum_1_Public_Utility_Equipment_RFP_110421 Mon September 20 2021 02:54 PM	<input checked="" type="checkbox"/>	1



CONTRACT EXTENSION

Contract Number: 110421-EEC

Sourcewell
202 12th Street Northeast
P.O. Box 219
Staples, MN 56479
(Sourcewell)

and

Elliott Equipment Company
3514 S 25th St

Omaha, Nebraska 68105
(Vendor)

have entered into Contract Number: 110421-EEC
for the procurement of: Public Utility Equipment with Related Accessories and Supplies

The Contract has an expiration date of 2025-12-27 , but the parties may extend the Contract by mutual consent.

Sourcewell and Vendor acknowledge that extending the Contract benefits the Vendor, Sourcewell and Sourcewell’s Members. Vendor and Sourcewell agree to extend the Contract listed above for an additional period, with a new Contract expiration date of 2026-12-27 . All other terms and conditions of the Contract remain in full force and effect.

Sourcewell

Signed by:

C0FD2A139D06489...
Authorized Signature

Jeremy Schwartz
Name

Chief Operating and Procurement Officer
Title

4/30/2025 | 3:51 PM CDT
Date

DocuSigned by:

F1997420D67A458...
Authorized Signature

Jim Glazer
Name

President & CEO
Title

4/30/2025 | 3:52 PM CDT
Date