



## Kenosha County Board of Supervisors Notice of Meeting

[Watch the meeting live stream.](#)

NOTE: UNDER THE KENOSHA COUNTY BOARD OF RULES OF PROCEDURE ANY REPORT, RESOLUTION, ORDINANCE OR MOTION APPEARING ON THIS AGENDA MAY BE AMENDED, WITHDRAWN, REMOVED FROM THE TABLE, RECONSIDERED OR RESCINDED IN WHOLE OR IN PART AT THIS OR AT FUTURE MEETINGS. NOTICE OF SUCH MOTIONS TO RECONSIDER OR RESCIND AT FUTURE MEETINGS SHALL BE GIVEN IN ACCORDANCE WITH SEC. 210(2) OF THE COUNTY BOARD RULES. FURTHERMORE, ANY MATTER DEEMED BY A MAJORITY OF THE BOARD TO BE GERMANE TO AN AGENDA ITEM MAY BE REFERRED TO THE PROPER COMMITTEE. ANY ITEM SCHEDULED FOR THE FIRST OF TWO READINGS IS SUBJECT TO A MOTION TO SUSPEND THE RULES IN ORDER TO PROCEED DIRECTLY TO DEBATE AND VOTE. ANY PERSON WHO DESIRES THE PRIVILEGE OF THE FLOOR PRIOR TO AN AGENDA ITEM BEING DISCUSSED SHOULD REQUEST A COUNTY BOARD SUPERVISOR TO CALL SUCH REQUEST TO THE ATTENTION OF THE BOARD CHAIRMAN.

**NOTICE IS HEREBY GIVEN** the **Regular County Board Meeting** of the Kenosha County Board of Supervisors will be held on **Tuesday, the 3rd of March, 2026, at 7:30 P.M.**, in the County Board Room located in the Kenosha County Administration Building, 1010 56th St, Kenosha, WI. The following will be the agenda for said meeting:

- A. Call To Order By Chairman Yuhas
- B. Pledge Of Allegiance
- C. Roll Call Of Supervisors
- D. Citizen Comments

Documents:

[GUIDELINES FOR CITIZEN COMMENTS FOR COUNTY BOARD AND COMMITTEE MEETINGS.PDF](#)

- E. Announcements Of The Chairperson
- F. Supervisor Reports
- G. NEW BUSINESS

Resolution - One Reading

172. From The Legislative Committee - A Resolution In Support Of Lowering Costs While Improving Health Outcomes For Incarcerated Individuals With Substance Use Disorders

Documents:

[SUPPORT LOWERING COSTS WHILE IMPROVING HEALTH OUTCOMES FOR INCARCERATED INDIVIDUALS WITH SUBSTANCE USE DISORDERS.PDF](#)

173. From The Legislative Committee - A Resolution Opposing Proposed Rulemaking Relating To Wireless Deployments

Documents:

[OPPOSING PROPOSED RULEMAKING RELATING TO WIRELESS DEPLOYMENTS.PDF](#)

174. From Public Works/Facilities Committee - A Resolution To Approve The Revision Of Rural Functional Classification System In Kenosha County

Documents:

[RESOLUTION TO REVISE RURAL ROADWAY FUNCTIONAL CLASSIFICATION IN KENOSHA COUNTY.PDF](#)

175. From Public Works/Facilities Committee - A Resolution Respectfully Requesting The Governor Of WI And State Legislature Enact A Comprehensive, Sustainable Transportation Funding Solution

Documents:

[RESOLUTION TO APPROVE REQUESTING THE GOVERNOR OF WI AND STATE LEGISLATURE TO ENACT A TRANSPORTATION FUNDING SOLUTION.PDF](#)

Ordinance - First Reading, Two Required

37. From The Legislative Committee - An Ordinance To Amend MCKC 2.02(3) Related To The Time Of The County Board Meetings

Documents:

[AMEND MCKC CHAPTER 2.02\(3\) RELATED TO TIME OF COUNTY BOARD MEETINGS.PDF](#)

## H. COMMUNICATIONS

128. Communication From The Public Works/Facilities Committee - A Resolution To Approve A Grant Submission To The DNRs Recreational Trails Program

Documents:

[DESIGN OF THE MIDWEST INTERSTATE TRAIL.PDF](#)

129. Communication From The Public Works/Facilities Committee - A Resolution To Maintain Wisconsin Bird City Status & Recognize International Migratory Bird Day Proclamation

Documents:

[WI BIRD CITY STATUS AND INTERNATIONAL MIGRATORY BIRD DAY.PDF](#)

130. Communication From The Judiciary & Law Enforcement Committee - A Resolution To Approve The PROBATIONARY CABARET LICENSE - Packard Enterprises DBA Greatlakes Dragway, 18411 1st St, Town Of Paris

Documents:

[COMMUNICATION FOR PROBATIONARY LICENSE.PDF](#)

131. Communication From The Finance & Administration Committee- County Consolidated Donation Policy

Documents:

[2026 CB COMMUNICATION - CONSOLIDATED DONATION POLICY.PDF](#)

132. Communication From Supervisor Franco And The Human Services Committee - A Resolution Recognizing April 27 - May 3, 2026, As "Fair Housing Week".

Documents:

[COMMUNICATION FOR 2026 FAIR HOUSING WEEK.PDF](#)

133. Communication From Supervisors Grady And Geertsen - A Resolution In Support Of Maintaining Sheridan Road As Currently Configured

Documents:

[MAINTAINING SHERIDAN ROAD AS CONFIGURED.PDF](#)

I. CLAIMS

64. Brian Massie - Property Damage

Documents:

[GL-07-26 MASSIE, BRIAN.PDF](#)

65. James Ungureanu - Property Damage

Documents:

[GL-08-26 UNGUREANU, JAMES.PDF](#)

J. Approval Of The February 18, 2026 County Board Meeting Minutes By Supervisor Gray

K. Adjourn

## **GUIDELINES FOR “CITIZEN COMMENTS” AT KENOSHA COUNTY BOARD AND COMMITTEE MEETINGS**

Please follow the guidelines for participating in Citizen Comments:

- Any person who wishes to address the county board during the “Citizen Comments” portion of the county board meeting must verbally state their name and residential address for the record.
- Citizens that speak during “Citizen Comments” must list their name and residential address on the sign-in sheet on the podium.
- Citizen Comments portion of the meeting will be for 1 hour, which may be adjusted by the County Board Chair at their discretion, if necessary.
- Each speaker is provided one opportunity to speak up to five (5) minutes in length or as announced by the County Board Chair at the beginning of the meeting. Stay within the time limits provided.
- Citizen comments should pertain to county operations.
- Comments should be made to the Board as a whole, and not to address individual Supervisors.
- Do not ask questions of the Board as a whole, or to individual supervisors, this is a time for public comments, not discussion or debate.
- Citizens must be courteous in their language and deportment and must avoid personalized remarks. Refraining from comments that are rude, obscene, or profane, personally attacking, or which demonstrate a lack of respect for others.
- The County Board Chair will not tolerate abusive language or disruptive behavior. The County Board Chair, for abusiveness or disruptive behavior, may terminate an individual’s public comments. The County Board Chair has the authority to rule speakers out of order for noncompliance with these guidelines and may call a short recess in disorderly situations.
- Citizens in the audience are not to audibly respond to comments being made or to make demonstrations either in support of or in opposition to a speaker or idea. Refraining from derogatory comments, inappropriate gesturing, or applause.



## KENOSHA COUNTY BOARD OF SUPERVISORS

Resolution No. \_\_\_\_\_

|   |                                  |  |                                      |
|---|----------------------------------|--|--------------------------------------|
| Subject:<br><br><p style="text-align: center;"><b>A Resolution in Support of Lowering Costs While Improving Health Outcomes for Incarcerated Individuals with Substance Use Disorders</b></p> |                                  |  |                                      |
| Original <input checked="" type="checkbox"/>  | Revised <input type="checkbox"/> | 2nd Correction <input type="checkbox"/>                | Resubmitted <input type="checkbox"/> |
| Date Submitted:   |                                  | Date Resubmitted:                                      |                                      |
| Submitted by: Erin Decker   |                                  |  |                                      |
| Fiscal Note Attached <input type="checkbox"/>   |                                  | Legal Note Attached <input type="checkbox"/> Agreement |                                      |
| Prepared by: Erin Decker  |                                  | Signature: <i>Erin Decker</i>                          |                                      |

**WHEREAS**, individuals lose their Medicaid coverage upon incarceration, creating significant barriers to accessing continuity of care and essential treatment upon release for those with substance use disorders; and

**WHEREAS**, the loss of Medicaid benefits during incarceration places the full financial responsibility for necessary health services provided in county jails on local governments; and

**WHEREAS**, Kenosha County budgeted \$4,847,092 in 2025 and \$5,449,810 in 2026 to provide medical care and pharmaceuticals for individuals housed in the Kenosha County Jail and Kenosha County Detention Center; and

**WHEREAS**, a University of Wisconsin study has demonstrated that removing barriers to outpatient healthcare needs and improving access to basic medical services are of particular importance for those with histories of substance use, and it may also help reduce high rates of post-release illness and overdose death in the initial weeks following release from incarceration; and

**WHEREAS**, initiating treatment prior to release and maintaining services throughout reentry provide incarcerated individuals with stability during a critical transition period, resulting in demonstrably improved health outcomes; and

**WHEREAS**, 2025 AB 604 and 2025 SB 598 direct the Wisconsin Department of Health Services to seek a federal Medicaid waiver to establish a state demonstration project that would provide eligible incarcerated individuals with up to 90 days of prerelease health care coverage, including case management, medication-assisted treatment for all substance use disorders, and a 30-day supply of prescription medications; and

**WHEREAS**, implementation of 2025 AB 604 and 2025 SB 598 would reduce financial pressures on local governments by shifting a portion of jail-related health care costs to the federal Medicaid program;

**NOW, THEREFORE, BE IT RESOLVED**, that the Kenosha County Board of Supervisors respectfully urges the Wisconsin State Legislature to support 2025 AB 604 and 2025 SB 598, relating to Medical Assistance coverage for eligible incarcerated individuals; and

**BE IT FURTHER RESOLVED**, that a copy of this resolution shall be forwarded to Kenosha County's Wisconsin legislative delegation, Governor Tony Evers, all Wisconsin counties, and the Wisconsin







---

Erin Decker

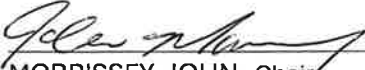
Approved by:

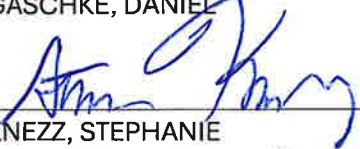
LEGISLATIVE COMMITTEE

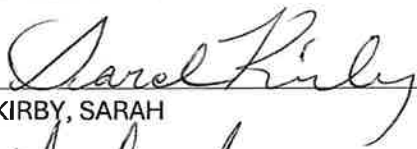
ONE BOX MUST ALWAYS BE CHECKED

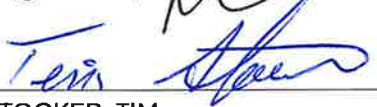
|   | AYE                                 | NAY                      | ABSTAIN                  | EXCUSED                  | UNEXCUSED                |
|---|-------------------------------------|--------------------------|--------------------------|--------------------------|--------------------------|
| <br>MORRISSEY, JOHN, Chair | <input checked="" type="checkbox"/> | <input type="checkbox"/> | <input type="checkbox"/> | <input type="checkbox"/> | <input type="checkbox"/> |
| <br>GASCHKE, DANIEL        | <input checked="" type="checkbox"/> | <input type="checkbox"/> | <input type="checkbox"/> | <input type="checkbox"/> | <input type="checkbox"/> |
| <br>KNEZZ, STEPHANIE       | <input checked="" type="checkbox"/> | <input type="checkbox"/> | <input type="checkbox"/> | <input type="checkbox"/> | <input type="checkbox"/> |
| <br>GARCIA, FELIX          | <input checked="" type="checkbox"/> | <input type="checkbox"/> | <input type="checkbox"/> | <input type="checkbox"/> | <input type="checkbox"/> |
| <br>KIRBY, SARAH          | <input checked="" type="checkbox"/> | <input type="checkbox"/> | <input type="checkbox"/> | <input type="checkbox"/> | <input type="checkbox"/> |
| <br>NORDIGIAN, MARK      | <input checked="" type="checkbox"/> | <input type="checkbox"/> | <input type="checkbox"/> | <input type="checkbox"/> | <input type="checkbox"/> |
| <br>STOCKER, TIM         | <input checked="" type="checkbox"/> | <input type="checkbox"/> | <input type="checkbox"/> | <input type="checkbox"/> | <input type="checkbox"/> |



KENOSHA COUNTY BOARD OF SUPERVISORS

RESOLUTION NO. \_\_\_\_\_

|   |   |
|---|---|
| Subject: A Resolution Opposing Proposed Rulemaking Relating to Wireless Deployments |   |
| Original <input type="checkbox"/>   | Corrected <input type="checkbox"/> 2 <sup>nd</sup> Correction <input type="checkbox"/> Resubmitted <input type="checkbox"/> |
| Date Submitted:   | Date Resubmitted:   |
| Submitted by: Supervisor Morrissey and the Legislative Committee                    |   |
| Fiscal Note Attached: <input type="checkbox"/>                                      | Legal Note Attached: <input type="checkbox"/>   |
| Prepared by: Supervisor John W. Morrissey<br>(Name, Title, Department or Division)  | Signature:                               |

A RESOLUTION TO OPPOSE PROPOSED FCC RULE-MAKING  
RELATING TO WIRELESS DEPLOYMENTS

WHEREAS, the Federal Communications Commission (FCC) has recently released a Notice of Proposed Rulemaking seeking comments on “reforms that would streamline the deployment of towers and other wireless infrastructure;” and

WHEREAS, the Kenosha County Board recognizes the importance of reliable wireless communications infrastructure to public safety, economic development, education, and quality of life; and

WHEREAS, while the need for and benefits of new infrastructure related to the expansion and improvement of the nation’s wireless capabilities may be a legitimate and laudable goal, there are serious concerns with the approach being contemplated by the FCC; and

WHEREAS, Congress, through Section 6409(a) of the Middle Class Tax Relief and Job Creation Act of 2012 (Spectrum Act), intended to streamline the collocation, removal, and replacement of wireless facilities while preserving an appropriate role for state and local governments; and

WHEREAS, the Federal Communications Commission (FCC) has proposed a rule change entitled "Build America: Eliminating Barriers to Wireless Deployments", which would significantly expand federal preemption over state and local authority; and

WHEREAS, State and local governments are best positioned to balance the need for wireless infrastructure with community planning goals, public safety considerations, environmental impacts, historic preservation, and neighborhood character; and

WHEREAS, this rule change appears to be based on the premise that local regulations unduly hinder such deployment; and

WHEREAS, it seems to fail to acknowledge the real interest that state and local governments have in regulating land use; and

WHEREAS, zoning authority, including such determinations as to the best and most appropriate land use, has historically rested with state governments under the framework established by the United States Supreme Court Case *Euclid v. Ambler*, (272 U.S. 365 (1926)) and then typically delegated to local jurisdictions, as being the authorities most appropriately situated to determine what is best for their communities, rather than having uniform standards imposed by the federal government; and

WHEREAS, the proposed rules seem to contemplate overriding such local determinations to a significant degree.

WHEREAS, Kenosha County supports cooperative efforts to expand broadband and wireless access, but believes such efforts should respect long-standing principles of local control:

NOW, THEREFORE, BE IT RESOLVED, that the Kenosha County Board urges United States Representative Bryan Steil and United States Senators Ron Johnson and Tammy Baldwin to oppose the proposed FCC rule change titled "Build America: Eliminating Barriers to Wireless Deployments"; and







BE IT FURTHER RESOLVED, that the Kenosha County Board respectfully requests that Wisconsin's federal delegation advocate for policies that promote wireless deployment without eliminating the authority of state and local governments to regulate land use and zoning in the public interest; and

BE IT FURTHER RESOLVED, that the Kenosha County Clerk is directed to transmit a copy of this resolution to Representative Bryan Steil, Senator Ron Johnson, Senator Tammy Baldwin, the Federal Communications Commission, and other appropriate parties.

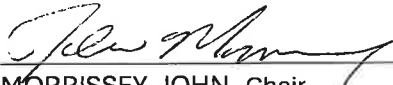
Approved by:

LEGISLATIVE COMMITTEE

ONE BOX MUST ALWAYS BE CHECKED

|   | AYE                                 | NAY                      | ABSTAIN                  | EXCUSED                  | UNEXCUSED                |
|---|-------------------------------------|--------------------------|--------------------------|--------------------------|--------------------------|
| <br>MORRISSEY, JOHN, Chair | <input checked="" type="checkbox"/> | <input type="checkbox"/> | <input type="checkbox"/> | <input type="checkbox"/> | <input type="checkbox"/> |
| <br>GASCHKE, DANIEL        | <input checked="" type="checkbox"/> | <input type="checkbox"/> | <input type="checkbox"/> | <input type="checkbox"/> | <input type="checkbox"/> |
| <br>KNEZZ, STEPHANIE       | <input checked="" type="checkbox"/> | <input type="checkbox"/> | <input type="checkbox"/> | <input type="checkbox"/> | <input type="checkbox"/> |
| <br>GARCIA, FELIX          | <input checked="" type="checkbox"/> | <input type="checkbox"/> | <input type="checkbox"/> | <input type="checkbox"/> | <input type="checkbox"/> |
| <br>KIRBY, SARAH          | <input checked="" type="checkbox"/> | <input type="checkbox"/> | <input type="checkbox"/> | <input type="checkbox"/> | <input type="checkbox"/> |
| <br>NORDIGIAN, MARK      | <input checked="" type="checkbox"/> | <input type="checkbox"/> | <input type="checkbox"/> | <input type="checkbox"/> | <input type="checkbox"/> |
| <br>STOCKER, TIM         | <input checked="" type="checkbox"/> | <input type="checkbox"/> | <input type="checkbox"/> | <input type="checkbox"/> | <input type="checkbox"/> |

Kenosha County  
Administrative Proposal Form



**1. Proposal Overview**

Division: Highway Department: Public Works

Proposal Summary (attach explanation and required documents):  
Resolution to revise Rural Roadway Functional Classification in Kenosha County

Dept./Division Head Signature: *Gregory J. Boldt* Date: 2/17/24  
Print Name: Gregory J. Boldt

**2. Department Head Review**

Comments:  
Recommendation: Approval  Non-Approval

Department Head Signature: *Shelly Billingsley* Date: 2-17-26  
Print Name: Shelly Billingsley

**3. Finance Division Review**

Comments:  
Recommendation: Approval  Non-Approval

Finance Signature: *Chris Walton* Date: 2-17-26  
Print Name: Chris Walton

**4. County Executive Review**

Comments:  
Action: Approval  Non-Approval

Executive Signature: *Samantha Kerkman* Date: 2/17/2024  
Print Name: Samantha Kerkman



KENOSHA COUNTY BOARD OF SUPERVISORS

RESOLUTION NO. \_\_\_\_\_

|  |   |
|--|---|
| Subject: Resolution to revise Rural Roadway Functional Classifications in Kenosha County   |   |
| Original <input checked="" type="checkbox"/>   | Corrected <input type="checkbox"/> 2 <sup>nd</sup> Correction <input type="checkbox"/> Resubmitted <input type="checkbox"/> |
| Date Submitted: 2/16/2026  | Date Resubmitted:   |
| Submitted by: Public Works/Facilities Committee and Finance/Administration Committee   |   |
| Fiscal Note Attached: <input type="checkbox"/>   | Legal Note Attached: <input type="checkbox"/>   |
| No Fiscal Impact: <input checked="" type="checkbox"/>  |   |
| Prepared by: Gregory J. Boldt, Director of Highways / Highway Commissioner, Department of Public Works<br><i>(Name, Title, Department or Division)</i> | Signature:  |

WHEREAS, functional classification is the method by which roads and streets are categorized based on the levels of mobility and access they provide; and

WHEREAS, functional classification categories are separate for Urban and Rural areas; and

WHEREAS, geographic areas not within a designated Urban Area (UA) are designated as Rural; and

WHEREAS, rural areas, for the purposes of functional classification, are defined by the county; and

WHEREAS, functional classification of a road or street has a bearing on federal transportation funding eligibility; and

WHEREAS, Federal Highway Administration (FHWA) and Wisconsin Department of Transportation (WisDOT) have developed guidance for functional classification of roads and streets; and

WHEREAS, WisDOT periodically reviews and updates the functional classification of roads and streets throughout the state; and

WHEREAS, these recommended functional classification changes were developed through joint review by Kenosha County officials and WisDOT planning staff; and

WHEREAS, documents showing the recommended functional classification changes are attached; and

WHEREAS, WisDOT will, after Kenosha County approval of the recommended functional classification changes, approve the changes and submit them to FHWA for final approval; and

WHEREAS, the approved final Functional Classification Map will be made available to Kenosha County after FHWA final approval; and

Resolution Regarding Change in Roadway Functional Classification  
Page 2

WHEREAS, the new functional classifications will supersede the existing functional classifications in the Urban and Rural area;

NOW, THEREFORE BE IT RESOLVED, that the Kenosha County Board of Supervisors approves the recommended functional classifications:







1. County Trunk Highway (CTH) C from CTH W to State Highway (STH) 83 – Minor Arterial to Principal Arterial
2. CTH C from STH 83 to United States Highway (USH) 45 – Major Collector to Minor Arterial
3. 83<sup>rd</sup> Street from 233<sup>rd</sup> Avenue to 216<sup>th</sup> Avenue – Local to Major Collector
4. 216<sup>th</sup> Avenue from 83<sup>rd</sup> Street to STH 50 – Local to Major Collector
5. CTH E from Interstate 94/41 (I-94/41) to CTH H – Major Collector to Minor Arterial
6. STH 83 from STH 50 to Racine County Line – Minor Arterial to Principal Arterial
7. 376<sup>th</sup> Avenue from STH 50 to Racine County Line – Local to Major Collector

Dated at Kenosha County, Wisconsin, this \_\_\_\_\_ day of \_\_\_\_\_, 2026.

Approved by:

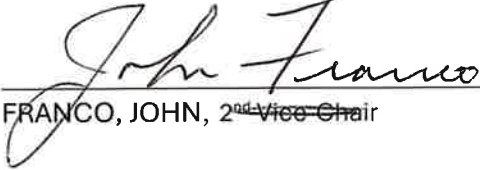
PUBLIC WORKS/FACILITIES COMMITTEE

ONE BOX MUST ALWAYS BE CHECKED

|   | AYE                                 | NAY                      | ABSTAIN                  | EXCUSED                             | UNEXCUSED                |
|---|-------------------------------------|--------------------------|--------------------------|-------------------------------------|--------------------------|
| <br>GRADY, WILLIAM, Chair                              | <input type="checkbox"/>            | <input type="checkbox"/> | <input type="checkbox"/> | <input type="checkbox"/>            | <input type="checkbox"/> |
| <br>BELSKY, LAURA, Vice-Chair                          | <input checked="" type="checkbox"/> | <input type="checkbox"/> | <input type="checkbox"/> | <input type="checkbox"/>            | <input type="checkbox"/> |
| <br>FRANCO, JOHN, <del>2<sup>nd</sup> Vice-Chair</del> | <input checked="" type="checkbox"/> | <input type="checkbox"/> | <input type="checkbox"/> | <input type="checkbox"/>            | <input type="checkbox"/> |
| _____<br>DECKER, ERIN   | <input type="checkbox"/>            | <input type="checkbox"/> | <input type="checkbox"/> | <input checked="" type="checkbox"/> | <input type="checkbox"/> |
| <br>GAMA, ANDRES                                     | <input checked="" type="checkbox"/> | <input type="checkbox"/> | <input type="checkbox"/> | <input type="checkbox"/>            | <input type="checkbox"/> |
| <br>GRAY, KEITH                                      | <input checked="" type="checkbox"/> | <input type="checkbox"/> | <input type="checkbox"/> | <input type="checkbox"/>            | <input type="checkbox"/> |
| <br>MEADOWS, ERIC                                    | <input checked="" type="checkbox"/> | <input type="checkbox"/> | <input type="checkbox"/> | <input type="checkbox"/>            | <input type="checkbox"/> |

# Kenosha County

## Functional Classification - Recommended Changes

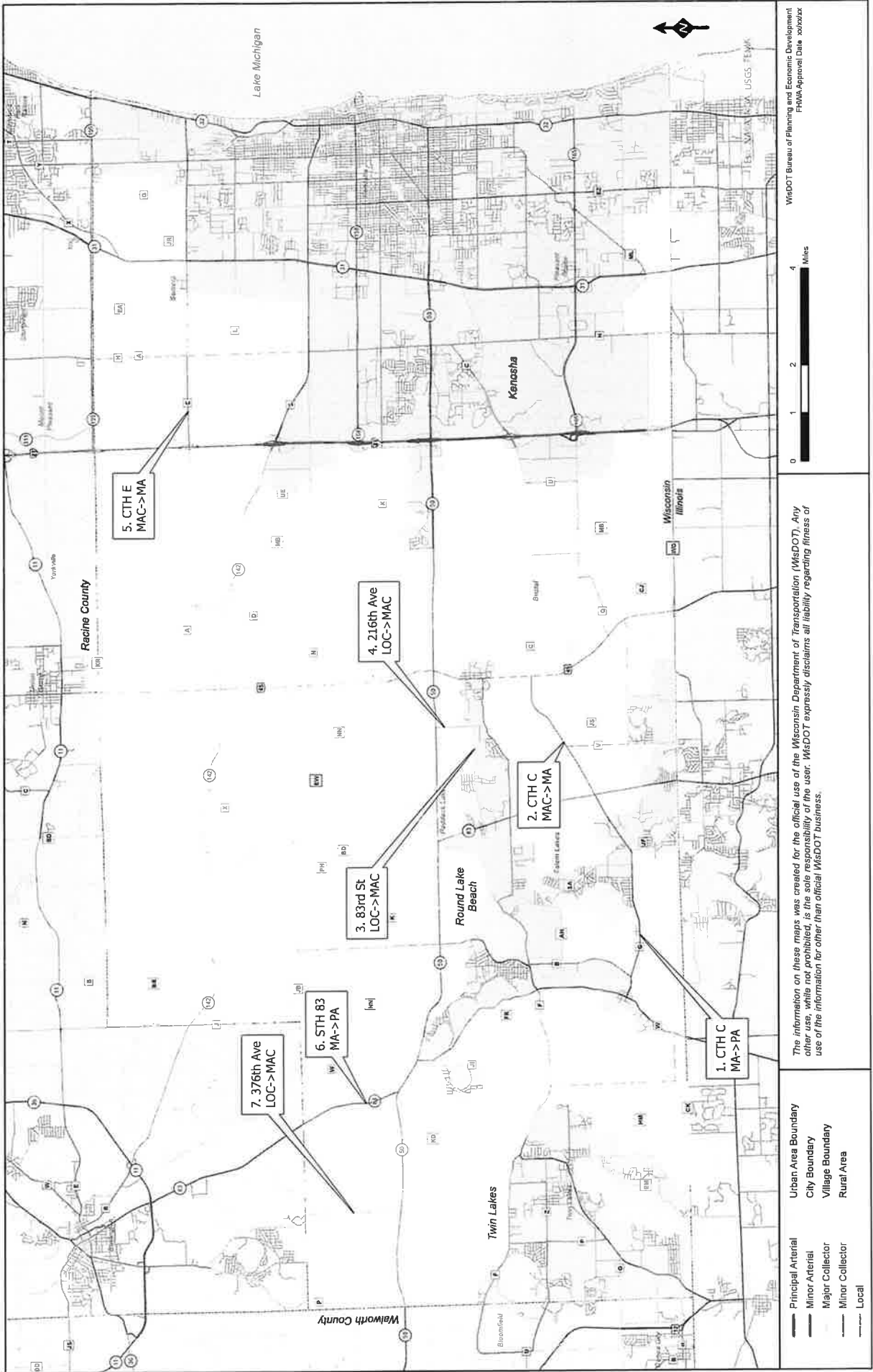

The information on these maps was created for the official use of the Wisconsin Department of Transportation (WisDOT). Any other use, while not prohibited, is the sole responsibility of the user. WisDOT expressly disclaims all liability regarding fitness of use of the information for other than official WisDOT business.

WisDOT Bureau of Planning and Economic Development  
 FEMA Approval Date: 10/20/20

RECOMMENDED FUNCTIONAL CLASSIFICATION CHANGES

WisDOT Region: South East (SE)  
 County: Kenosha  
 County Population Density: High

County: **KENOSHA COUNTY**

Starting Mileage: TOTAL 354.99

| No. | Route                            | Limits                      | From |      | To  |     | IH   | PA    | MA    | MAC   | MIC   | LOC    | Reason  |
|-----|----------------------------------|-----------------------------|------|------|-----|-----|------|-------|-------|-------|-------|--------|---|
|     |                                  |                             | rMA  | rMAC | rPA | rMA |      |       |       |       |       |        |   |
| 1   | CTH C - Kenosha County           | CTH C - STH 83              | rMA  | rMAC | rPA | rMA | 3.91 | 26.69 | 40.07 | 67.34 | 30.67 | 186.31 |   |
| 2   | CTH C - Kenosha County           | CTH C - USH 45              | rMA  | rMAC | rMA | rMA |      |       |       |       |       |        | AADT is in the PA range (1800), reduces MA mileage which is high                        |
| 3   | 83rd St - Village of Salem Lakes | 233rd Ave - 216th Ave       | rLOC | rMAC | rMA | rMA |      |       |       |       |       |        | Continuity Improvement, MAC Upgrading   |
| 4   | 216th Ave - Village of Bristol   | 93rd St - STH 50            | rLOC | rMAC | rMA | rMA |      |       |       |       |       |        | Continuity Improvement  |
| 5   | CTH E - Kenosha County           | M43 - CTH H                 | rMA  | rMAC | rMA | rMA |      |       |       |       |       |        | AADT is in the MA range (1800), continuity improvement (connects segment to Interstate) |
| 6   | STH 83 - WisDOT                  | STH 50 - Racine County Line | rMA  | rMAC | rPA | rMA |      |       |       |       |       |        | AADT is in the PA range (5300), reduces MA mileage which is high                        |
| 7   | 376th Ave - Town of Wheatland    | STH 50 - Racine County Line | rLOC | rMAC | rMA | rMA |      |       |       |       |       |        | Continuity Improvement  |
| 8   |                                  |                             |      |      |     |     |      |       |       |       |       |        |   |
| 9   |                                  |                             |      |      |     |     |      |       |       |       |       |        |   |
| 10  |                                  |                             |      |      |     |     |      |       |       |       |       |        |   |
| 11  |                                  |                             |      |      |     |     |      |       |       |       |       |        |   |
| 12  |                                  |                             |      |      |     |     |      |       |       |       |       |        |   |
| 13  |                                  |                             |      |      |     |     |      |       |       |       |       |        |   |
| 14  |                                  |                             |      |      |     |     |      |       |       |       |       |        |   |
| 15  |                                  |                             |      |      |     |     |      |       |       |       |       |        |   |
| 16  |                                  |                             |      |      |     |     |      |       |       |       |       |        |   |
| 17  |                                  |                             |      |      |     |     |      |       |       |       |       |        |   |
| 18  |                                  |                             |      |      |     |     |      |       |       |       |       |        |   |
| 19  |                                  |                             |      |      |     |     |      |       |       |       |       |        |   |
| 20  |                                  |                             |      |      |     |     |      |       |       |       |       |        |   |
| 21  |                                  |                             |      |      |     |     |      |       |       |       |       |        |   |

Change: 0 3.74 1.69 -1.62 0 -3.81 0.00

End Mileage: 3.91 30.43 41.76 65.72 30.67 182.5 354.99

End %: 1.1% 8.6% 11.8% 18.5% 8.6% 51.4%  
 Mileage range: 1% - 3% 2% - 4% 2% - 6% 8% - 16% 5% - 15% 62% - 74%

Kenosha County  
Administrative Proposal Form



**1. Proposal Overview**

Division: Highway Department: Public Works

Proposal Summary (attach explanation and required documents):

Resolution respectfully requesting the Governor of Wisconsin and State Legislature enact a comprehensive, sustainable transportation funding solution.

Dept./Division Head Signature: *Gregory J. Boldt* Date: 2/17/26  
Print Name: Gregory J. Boldt

**2. Department Head Review**

Comments:

Recommendation: Approval  Non-Approval

Department Head Signature: *Shelly Billingsley* Date: 2-17-26  
Print Name: Shelly Billingsley

**3. Finance Division Review**

Comments:

Recommendation: Approval  Non-Approval

Finance Signature: *Chris Walton* Date: 2-17-26  
Print Name: Chris Walton

**4. County Executive Review**

Comments:

Action: Approval  Non-Approval

Executive Signature: *Samantha Kerkman* Date: 2/17/2024  
Print Name: Samantha Kerkman



KENOSHA COUNTY BOARD OF SUPERVISORS

RESOLUTION NO. \_\_\_\_\_

|   |   |
|---|---|
| Subject: Resolution respectfully requesting the Governor of Wisconsin and State Legislature enact a comprehensive, sustainable transportation funding solution.           |   |
| Original <input checked="" type="checkbox"/>  | Corrected <input type="checkbox"/> 2 <sup>nd</sup> Correction <input type="checkbox"/> Resubmitted <input type="checkbox"/> |
| Date Submitted: 2/16/2026   | Date Resubmitted:   |
| Submitted by: Public Works/Facilities Committee and Finance/Administration Committee  |   |
| Fiscal Note Attached: <input type="checkbox"/>  | Legal Note Attached: <input type="checkbox"/>   |
| No Fiscal Impact: <input checked="" type="checkbox"/>   |   |
| Prepared by: Gregory J. Boldt, Director of Highways / Highway Commissioner, Department of Public Works / Highway Division<br><i>(Name, Title, Department or Division)</i> | Signature:  |

WHEREAS, local units of government in Wisconsin own and maintain approximately 90% of the public road miles in the state, including county highways, town roads, and city and village streets; and

WHEREAS, there are approximately 1,010 miles of locally owned and maintained roadways in Kenosha County; and

WHEREAS, Kenosha County owns and maintains 252 miles of roadways; and

WHEREAS, Wisconsin's economy—rooted in agriculture, manufacturing, and tourism—relies on a safe, reliable, and well-maintained transportation network; and

WHEREAS, local governments greatly appreciate the one-time infusions of General Purpose Revenue, primarily sales and income taxes, and other revenue provided in recent state budgets, which have enabled the initiation and continuation of the successful and popular Local Roads Improvement Program Supplemental (LRIP-S) and Agricultural Roads Improvement Program (ARIP); and

WHEREAS, the most recent Wisconsin State Budget included an increase in General Transportation Aid (GTA) additional increases are necessary to keep pace with inflation, labor costs, materials costs, and construction costs; and

WHEREAS, despite modest increases from the state over the years, transportation aids to local governments remain insufficient to keep pace with inflation and rising construction costs, leaving many communities funded below 2000 levels in real dollars; and

WHEREAS, local governments throughout Wisconsin continue to struggle to perform even routine maintenance, pavement preservation, and safety improvements, resulting in deteriorating roads and bridges; and

WHEREAS, the inaugural inventory and assessment of small bridges between 6 to 20 feet found about 10% of the nearly 17,000 structures to be in poor or severe condition; and

WHEREAS, there are 67 small bridges in Kenosha County with 13% in poor or worse condition and 25% have moderate or more severe damage; and

WHEREAS, levy limits and other fiscal constraints prevent local governments from independently filling the funding gap created by inadequate state transportation aids; and

WHEREAS, absent sustainable state funding, many communities have been forced to address their shortfalls by significantly increasing borrowing, deferring essential projects, or imposing local vehicle registration (“wheel”) taxes; and

WHEREAS, Wisconsin motorists currently pay among the lowest transportation user fees in the Midwest, while neighboring states and dozens of others nationwide have enacted long-term revenue measures to keep their transportation systems competitive; and

WHEREAS, Wisconsin is increasingly relying on General Purpose Revenues to make needed investments, potentially pitting transportation against other vital services, such as health care and education; and

WHEREAS, continued lack of growing, dedicated, and predictable revenue places Wisconsin at a growing economic disadvantage by threatening the efficiency of freight movement, the safety of travelers, and the attractiveness of our state to businesses and residents; and

WHEREAS, both Wisconsin’s aging Interstate highway system—largely constructed in the 1950s and 1960s—and our extensive network of state and local roads require predictable, adequate, and sustainable funding to meet current and future needs; and

WHEREAS, Kenosha County maintains approximately 95 miles of state roadways and 12 miles of interstate roadway;

NOW, THEREFORE, BE IT RESOLVED that the Kenosha County Board of Supervisors respectfully requests the Governor of Wisconsin and the State Legislature enact a comprehensive, sustainable transportation funding solution that:

1. Provides adequate and reliable revenue growth for the efficient long-term planning and execution of state and local transportation programs;
2. Includes responsible and prudent use of General Purpose Revenue and bonding;
3. Adjusts any new and existing transportation user fees and other revenue mechanisms to sustain purchasing power in order to maintain and improve Wisconsin’s transportation infrastructure; and
4. Ensures transportation continues to deliver for Wisconsin by adequately funding reconstruction, preservation, and safety investments on the state and local systems.







BE IT FURTHER RESOLVED that the clerk is hereby directed to transmit a copy of this resolution to the Governor’s office, all members of the Wisconsin State Senate and Assembly representing districts within Kenosha County, and the Wisconsin Counties Association.

Dated at Kenosha County, Wisconsin, this \_\_\_\_\_ day of \_\_\_\_\_, 2026.

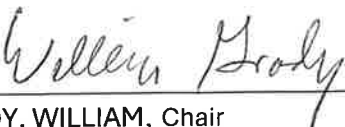
Approved by:

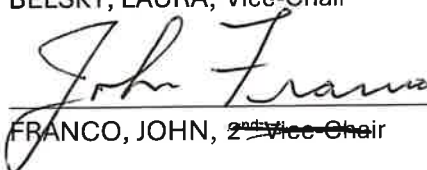
PUBLIC WORKS/FACILITIES COMMITTEE

**ONE BOX MUST ALWAYS BE CHECKED**

|  | AYE                                 | NAY                      | ABSTAIN                  | EXCUSED                             | UNEXCUSED                |
|--|-------------------------------------|--------------------------|--------------------------|-------------------------------------|--------------------------|
| <br>_____<br>GRADY, WILLIAM, Chair                              | <input type="checkbox"/>            | <input type="checkbox"/> | <input type="checkbox"/> | <input type="checkbox"/>            | <input type="checkbox"/> |
| <br>_____<br>BELSKY, LAURA, Vice-Chair                          | <input checked="" type="checkbox"/> | <input type="checkbox"/> | <input type="checkbox"/> | <input type="checkbox"/>            | <input type="checkbox"/> |
| <br>_____<br>FRANCO, JOHN, <del>2<sup>nd</sup></del> Vice-Chair | <input checked="" type="checkbox"/> | <input type="checkbox"/> | <input type="checkbox"/> | <input type="checkbox"/>            | <input type="checkbox"/> |
| _____<br>DECKER, ERIN  | <input type="checkbox"/>            | <input type="checkbox"/> | <input type="checkbox"/> | <input checked="" type="checkbox"/> | <input type="checkbox"/> |
| <br>_____<br>GAMA, ANDRES                                     | <input checked="" type="checkbox"/> | <input type="checkbox"/> | <input type="checkbox"/> | <input type="checkbox"/>            | <input type="checkbox"/> |
| <br>_____<br>GRAY, KEITH                                      | <input checked="" type="checkbox"/> | <input type="checkbox"/> | <input type="checkbox"/> | <input type="checkbox"/>            | <input type="checkbox"/> |
| <br>_____<br>MEADOWS, ERIC                                    | <input checked="" type="checkbox"/> | <input type="checkbox"/> | <input type="checkbox"/> | <input type="checkbox"/>            | <input type="checkbox"/> |



KENOSHA COUNTY BOARD OF SUPERVISORS

ORDINANCE NO. \_\_\_\_\_

|   |   |
|---|---|
| Subject: An Ordinance to Amend MCKC Chapter 2.02 (3) related to time of County Board regular meetings |   |
| Original <input type="checkbox"/>   | Corrected <input type="checkbox"/> 2 <sup>nd</sup> Correction <input type="checkbox"/> Resubmitted <input type="checkbox"/> |
| Date Submitted: 2-19-20   | Date Resubmitted:   |
| Submitted by: Supervisor Nudo and the Legislative Committee   |   |
| Fiscal Note Attached: <input type="checkbox"/>  | Legal Note Attached: <input type="checkbox"/>   |
| Prepared by: Supervisor Gabe Nudo<br>(Name, Title, Department or Division)                            | Signature:  |

AN ORDINANCE TO AMEND MCKC CHAPTER 2.02 (3)





THE KENOSHA COUNTY BOARD OF SUPERVISORS DOES HEREBY ORDAIN that Municipal Code of Kenosha County Chapter 2.02(3), the County Board Rules of Procedure is hereby amended as follows:

(3) *Regular Meetings*. In addition to the organizational and annual meetings, the County Board shall meet at ~~7:30~~ ~~6:30~~ 7:00 p.m. on the first and third Tuesday of each month for the purpose of transacting business. The Chair, in his or her discretion, may cancel a regular meeting for any reason, including, but not limited to: a lack of agenda items, inclement weather, or other unforeseen circumstances. The Board Chair shall provide reasonably adequate notice to the supervisors and the public in advance of any such meeting cancellation.

Approved by:

LEGISLATIVE COMMITTEE

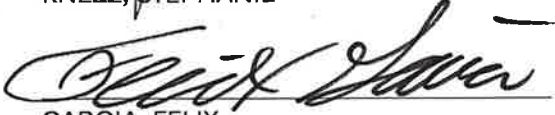
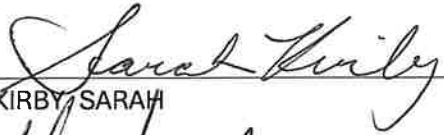
**ONE BOX MUST ALWAYS BE CHECKED**

|   | AYE                                 | NAY                      | ABSTAIN                  | EXCUSED                  | UNEXCUSED                |
|---|-------------------------------------|--------------------------|--------------------------|--------------------------|--------------------------|
| <br>MORRISSEY, JOHN, Chair | <input checked="" type="checkbox"/> | <input type="checkbox"/> | <input type="checkbox"/> | <input type="checkbox"/> | <input type="checkbox"/> |
| <br>GASCHKE, DANIEL        | <input checked="" type="checkbox"/> | <input type="checkbox"/> | <input type="checkbox"/> | <input type="checkbox"/> | <input type="checkbox"/> |
| <br>KNEZZ, STEPHANIE     | <input checked="" type="checkbox"/> | <input type="checkbox"/> | <input type="checkbox"/> | <input type="checkbox"/> | <input type="checkbox"/> |
| <br>GARCIA, FELIX        | <input checked="" type="checkbox"/> | <input type="checkbox"/> | <input type="checkbox"/> | <input type="checkbox"/> | <input type="checkbox"/> |
| <br>KIRBY, SARAH         | <input checked="" type="checkbox"/> | <input type="checkbox"/> | <input type="checkbox"/> | <input type="checkbox"/> | <input type="checkbox"/> |
| <br>NORDIGIAN, MARK      | <input checked="" type="checkbox"/> | <input type="checkbox"/> | <input type="checkbox"/> | <input type="checkbox"/> | <input type="checkbox"/> |
| <br>STOCKER, TIM         | <input checked="" type="checkbox"/> | <input type="checkbox"/> | <input type="checkbox"/> | <input type="checkbox"/> | <input type="checkbox"/> |



## **MEMORANDUM**

Communication to Kenosha County Board of Supervisors  
(For Informational Purposes Only)

***COMMUNICATION TO APPEAR ON COUNTY BOARD MEETING AGENDA: 03/03/2026***

***SUBJECT: Resolution to Approve a Grant Submission to the DNR's Recreational Trails Program for Funding the Design of the Midwest Interstate Trail***

***SUBMITTED BY: Wyatt Moore***

***TO BE REFERRED TO: Public Works/Facilities Committee and Finance/Administration Committee***

***ADDITIONAL INFORMATION (optional):***



## **MEMORANDUM**

Communication to Kenosha County Board of Supervisors  
(For Informational Purposes Only)

***COMMUNICATION TO APPEAR ON COUNTY BOARD MEETING AGENDA: 03/03/2026***

***SUBJECT: Resolution to Maintain Wisconsin Bird City Status & Recognize International Migratory Bird Day Proclamation***

***SUBMITTED BY: Wyatt Moore***

***TO BE REFERRED TO: Public Works/Facilities Committee and Finance/Administration Committee***

***ADDITIONAL INFORMATION (optional):***



## **MEMORANDUM**

Communication to Kenosha County Board of Supervisors  
(For Informational Purposes Only)

***COMMUNICATION TO APPEAR ON COUNTY BOARD MEETING AGENDA: 03/03/2026***

***SUBJECT: Communication from the Judiciary & Law Enforcement Committee – A Resolution to Approve the Probationary Cabaret License – Packard Enterprises DBA Greatlakes Dragway, 18411 1<sup>st</sup> St, Town of Paris***

***SUBMITTED BY: Captain Beranis***

***TO BE REFERRED TO: Judiciary & Law Enforcement Committee***

***ADDITIONAL INFORMATION (optional):***



## **MEMORANDUM**

Communication to Kenosha County Board of Supervisors  
(For Informational Purposes Only)

***COMMUNICATION TO APPEAR ON COUNTY BOARD MEETING AGENDA: 03/03/2026***

***SUBJECT:*** County Consolidated Donation Policy

***SUBMITTED BY:*** Barna Bencs Budget Director

***TO BE REFERRED TO:*** Finance & Administration Committee on 3/12/2026

***ADDITIONAL INFORMATION (optional):***



## **MEMORANDUM**

Communication to Kenosha County Board of Supervisors  
(For Informational Purposes Only)

***COMMUNICATION TO APPEAR ON COUNTY BOARD MEETING AGENDA: 03/03/2026***

***SUBJECT: A Resolution Recognizing April 27 - May 3, 2026, as "Fair Housing Week".***

***SUBMITTED BY: Supervisor Franco and the Human Services Committee***

***TO BE REFERRED TO: Human Services Committee***

***ADDITIONAL INFORMATION (optional):***



1  
2  
3  
4  
5  
6  
7  
8  
9  
10  
11  
12  
13  
14  
15  
16  
17  
18  
19  
20  
21  
22  
23  
24  
25

KENOSHA COUNTY BOARD OF SUPERVISORS

RESOLUTION NO. \_\_\_\_\_

|  |   |
|--|---|
| Subject: A Resolution Recognizing April 27-May 3, 2026, as “Fair Housing Week” |   |
| Original <input type="checkbox"/>  | Corrected <input type="checkbox"/> 2 <sup>nd</sup> Correction <input type="checkbox"/> Resubmitted <input type="checkbox"/> |
| Date Submitted:  | Date Resubmitted:   |
| Submitted by: Supervisor Franco and the Human Services Committee               |   |
| Fiscal Note Attached: <input type="checkbox"/>                                 | Legal Note Attached: <input type="checkbox"/>   |
| Prepared by: Supervisor Franco<br>(Name, Title, Department or Division)        | Signature:  |

A RESOLUTION RECOGNIZING APRIL 27-May 3, 2026,  
AS FAIR HOUSING WEEK IN KENOSHA COUNTY

WHEREAS, it is important to reaffirm the commitment of Kenosha County regarding citizens’ rights to buy, sell, rent or otherwise secure housing in Kenosha County without regard to sex, race, religion, marital status, age, national origin, income or financial status in conformance with Title VIII of the Civil Rights Action of 1968, a/k/a the Federal Fair Housing Law and State Open Housing Law; and

WHEREAS, fair housing occurs when people have a wide range of housing choices based on their income and needs, and background or circumstances; and

WHEREAS, Kenosha County’s commitment to fair housing and the availability of housing for all is demonstrated in its ongoing involvement in the Kenosha County Housing Task Force.

NOW, THEREFORE, BE IT RESOLVED that the Kenosha County Board of Supervisors hereby recognizes April 27-May 3, 2026, as Fair Housing Week in Kenosha County; and

BE IT FURTHER RESOLVED that the Kenosha County Board of Supervisors commends all those who have been involved with the struggle for fair housing, and wishes all continued success in breaking the barriers that limit the realization of equal housing opportunity for everyone.

26

27 Resolution Recognizing April 27-May 3, 2026, as “Fair Housing Week”

28 Page 2

29

30 \_\_\_\_\_

31 John Franco

32 Approved by:

33

34 HUMAN SERVICES COMMITTEE

35

**ONE BOX MUST ALWAYS BE CHECKED**

36

|  | AYE | NAY | ABSTAIN | EXCUSED | UNEXCUSED |
|--|-----|-----|---------|---------|-----------|
|--|-----|-----|---------|---------|-----------|

37

|       |                          |                          |                          |                          |                          |
|-------|--------------------------|--------------------------|--------------------------|--------------------------|--------------------------|
| _____ | <input type="checkbox"/> | <input type="checkbox"/> | <input type="checkbox"/> | <input type="checkbox"/> | <input type="checkbox"/> |
|-------|--------------------------|--------------------------|--------------------------|--------------------------|--------------------------|

40 FRANCO, JOHN, Chair

41

42

|       |                          |                          |                          |                          |                          |
|-------|--------------------------|--------------------------|--------------------------|--------------------------|--------------------------|
| _____ | <input type="checkbox"/> | <input type="checkbox"/> | <input type="checkbox"/> | <input type="checkbox"/> | <input type="checkbox"/> |
|-------|--------------------------|--------------------------|--------------------------|--------------------------|--------------------------|

44 KIRBY, SARAH, Vice Chair

45

46

|       |                          |                          |                          |                          |                          |
|-------|--------------------------|--------------------------|--------------------------|--------------------------|--------------------------|
| _____ | <input type="checkbox"/> | <input type="checkbox"/> | <input type="checkbox"/> | <input type="checkbox"/> | <input type="checkbox"/> |
|-------|--------------------------|--------------------------|--------------------------|--------------------------|--------------------------|

48 BROWN, GUIDA

49

50

|       |                          |                          |                          |                          |                          |
|-------|--------------------------|--------------------------|--------------------------|--------------------------|--------------------------|
| _____ | <input type="checkbox"/> | <input type="checkbox"/> | <input type="checkbox"/> | <input type="checkbox"/> | <input type="checkbox"/> |
|-------|--------------------------|--------------------------|--------------------------|--------------------------|--------------------------|

52 KNEZZ, STEPHANIE

53

54

|       |                          |                          |                          |                          |                          |
|-------|--------------------------|--------------------------|--------------------------|--------------------------|--------------------------|
| _____ | <input type="checkbox"/> | <input type="checkbox"/> | <input type="checkbox"/> | <input type="checkbox"/> | <input type="checkbox"/> |
|-------|--------------------------|--------------------------|--------------------------|--------------------------|--------------------------|

56 NORDIGIAN, MARK

57

58

|       |                          |                          |                          |                          |                          |
|-------|--------------------------|--------------------------|--------------------------|--------------------------|--------------------------|
| _____ | <input type="checkbox"/> | <input type="checkbox"/> | <input type="checkbox"/> | <input type="checkbox"/> | <input type="checkbox"/> |
|-------|--------------------------|--------------------------|--------------------------|--------------------------|--------------------------|

60 POOLE, JOHN

61

62

|       |                          |                          |                          |                          |                          |
|-------|--------------------------|--------------------------|--------------------------|--------------------------|--------------------------|
| _____ | <input type="checkbox"/> | <input type="checkbox"/> | <input type="checkbox"/> | <input type="checkbox"/> | <input type="checkbox"/> |
|-------|--------------------------|--------------------------|--------------------------|--------------------------|--------------------------|

64 ROBINSON, JULIA



## **MEMORANDUM**

Communication to Kenosha County Board of Supervisors  
(For Informational Purposes Only)

***COMMUNICATION TO APPEAR ON COUNTY BOARD MEETING AGENDA: 03/02/2026***

***SUBJECT: Resolution in Support with the Village of Somers for the Maintaining of Sheridan Road as Configured***

***SUBMITTED BY: Supervisor Geertsen and Supervisor Grady***

***TO BE REFERRED TO: Public Works/Facilities Committee***

***ADDITIONAL INFORMATION (optional):***



1  
2  
3  
4  
5  
6  
7  
8  
9  
10  
11  
12  
13  
14  
15  
16  
17  
18  
19  
20  
21  
22  
23  
24  
25  
26  
27  
28  
29  
30  
31  
32  
33  
34  
35

KENOSHA COUNTY BOARD OF SUPERVISORS

RESOLUTION NO. \_\_\_\_\_

|  |   |
|--|---|
| Subject: Resolution in Support with the Village of Somers for the Maintaining of Sheridan Road as Configured |   |
| Original <input checked="" type="checkbox"/>   | Corrected <input type="checkbox"/> 2 <sup>nd</sup> Correction <input type="checkbox"/> Resubmitted <input type="checkbox"/> |
| Date Submitted: 2/26/2026  | Date Resubmitted:   |
| Submitted by: Supervisor Geertsen and Supervisor Grady   |   |
| Fiscal Note Attached: <input type="checkbox"/>   | Legal Note Attached: <input checked="" type="checkbox"/>  |
| No Fiscal Impact: <input type="checkbox"/>   |   |
| Prepared by: Supervisor Geertsen and Supervisor Grady  |   |

WHEREAS, planning is underway for a project to reconstruct Sheridan Road; and

WHEREAS, this reconstruction would impact Sheridan Road between Alford Drive in Kenosha and 21st Street in Racine; and

WHEREAS, officials from the Wisconsin Department of Transportation (DOT) met with officials from the Village of Somers to present alternative plans for the reconstruction; and

WHEREAS, three options were presented: Option 1, which would replace the road as currently configured; Option 2, which would reduce four travel lanes to two, with a center left turn lane; and Option 3, which would reduce four lanes to two with a center turn lane and a sidewalk on the east side; and

WHEREAS, the Village of Somers indicated their concerns regarding Options 2 and 3 including that the addition of proposed on-road bike lanes would cause additional safety concerns and the reduction of lanes would negatively impact safety, and expressed their belief that any increased incidents of accidents on that roadway were not due to road design issues but were the result of other causes which would be unaddressed by the proposed changes to the road design; and

WHEREAS, accordingly, the Village of Somers supports maintaining Sheridan Road as currently configured, with four lanes of traffic, otherwise identified as Option 1; and

WHEREAS, the Village of Somers requests that the Kenosha County Board of Supervisors likewise support Option 1; and

WHEREAS, the Village of Somers has demonstrated its commitment to enhanced traffic safety on both STH 31 and STH 32 by implementing:

- a) a permanently increased number of hours of traffic safety patrol
- b) permanently installed 'moving radar' units into all squad car units to accurately enforce speed limits
- c) selectively expended overtime funds to monitor/enforce traffic laws

36 d) conducted quarterly traffic evaluation enforcement meetings involving Village of Somers: president, fire  
37 chief, trustee(s), concerned citizens. Also in attendance Kenosha county: sheriff, deputies, director of  
38 highways, public works committee chairman, county supervisor(s), and  
39

40 WHEREAS, the above referenced paragraph is not a short term remedy but rather serves as a template  
41 for enhanced traffic enforcement that is to budgeted in the upcoming fiscal cycle; and  
42

43 WHEREAS, with the 35 mph speed reduction signage provided by the Wisconsin DOT, and local traffic  
44 enforcement, vehicular traffic speed has had a notable reduction. These observations are both anecdotal  
45 and have been recorded by the DOT in a series of traffic speed studies; and  
46

47 WHEREAS, the number/severity of vehicular crashes on STH 32, within the speed reduction area have  
48 been notably reduced as reported by Kenosha Sheriff Office( KSO); and,  
49

50 WHEREAS, Kenosha County has in the past (and currently) a long-standing commitment to alternative  
51 forms of transportation in the form of both shared and dedicated travel lanes for pedestrians/bicyclists.  
52 NOTE: There exists a dedicated paved bike/pedestrian trail approximately 0.4 mi. west of the STH 32  
53 study area. It parallels STH 32 and continues into Racine county; and  
54

55 WHEREAS, Kenosha County highway department has a longstanding policy of providing an additional  
56 paved area adjacent to new/existing roadways when being constructed. This additional paving is most  
57 often done on both sides of the road adjacent to the gravel shoulder and is intended to give additional  
58 separation between motorists and pedestrians/bicyclists; and  
59

60 WHEREAS, Kenosha and Racine counties are noting substantial population growth, motor vehicle traffic  
61 is on the rise and will only continue to increase. Businesses and commuters depend on this road as a  
62 main thoroughfare. Reducing vehicular travel lanes at this time, on this road appears to many as  
63 counterintuitive. The thoughts and intents of the DOT are well reasoned and intentioned. There is an  
64 understanding in Kenosha County of what DOT is trying to accomplish, namely safer roadways. By  
65 paying attention to the aforementioned safety needs and balancing them with need for a vital four travel  
66 lane road, we respectfully submit the following for your approval,  
67  
68

69 NOW THEREFORE BE IT RESOLVED that the Kenosha County Board of Supervisors supports  
70 maintaining Sheridan Road as currently configured, with four lanes of traffic, otherwise identified as  
71 Option 1; and  
72

73 **BE IT FURTHER RESOLVED**, that a copy of this resolution shall be forwarded to Kenosha County's  
74 state legislative delegation, Racine County Board, Racine City Council, Village of Mount Pleasant, City of  
75 Kenosha, Village of Pleasant Prairie, Wisconsin Department of Transportation.  
76  
77

78 \_\_\_\_\_  
79 David Geertsen

\_\_\_\_\_ William Grady

**ONE BOX MUST ALWAYS BE CHECKED**

|   | AYE                      | NAY                      | ABSTAIN                  | EXCUSED                  | UNEXCUSED                |
|---|--------------------------|--------------------------|--------------------------|--------------------------|--------------------------|
| _____<br>GRADY, WILLIAM, Chair                    | <input type="checkbox"/> | <input type="checkbox"/> | <input type="checkbox"/> | <input type="checkbox"/> | <input type="checkbox"/> |
| _____<br>BELSKY, LAURA, Vice-Chair                | <input type="checkbox"/> | <input type="checkbox"/> | <input type="checkbox"/> | <input type="checkbox"/> | <input type="checkbox"/> |
| _____<br>FRANCO, JOHN, 2 <sup>nd</sup> Vice-Chair | <input type="checkbox"/> | <input type="checkbox"/> | <input type="checkbox"/> | <input type="checkbox"/> | <input type="checkbox"/> |
| _____<br>DECKER, ERIN                             | <input type="checkbox"/> | <input type="checkbox"/> | <input type="checkbox"/> | <input type="checkbox"/> | <input type="checkbox"/> |
| _____<br>GAMA, ANDRES                             | <input type="checkbox"/> | <input type="checkbox"/> | <input type="checkbox"/> | <input type="checkbox"/> | <input type="checkbox"/> |
| _____<br>GRAY, KEITH                              | <input type="checkbox"/> | <input type="checkbox"/> | <input type="checkbox"/> | <input type="checkbox"/> | <input type="checkbox"/> |
| _____<br>MEADOWS, ERIC                            | <input type="checkbox"/> | <input type="checkbox"/> | <input type="checkbox"/> | <input type="checkbox"/> | <input type="checkbox"/> |



# KENOSHA COUNTY

Regi Waligora, County Clerk

6L-07-26

## CLAIM AGAINST KENOSHA COUNTY

FULL NAME Brian Massie DATE 2-16-26

ADDRESS 4234 75T  
Kenosha WI 53144

TELEPHONE NUMBER: 262-308-2297

DATE & TIME OF ACCIDENT OR LOSS 2-8-26

LOCATION OF ACCIDENT Night time plowing  
4234 75T  
Kenosha WI 53144

DESCRIPTION OF ACCIDENT OR LOSS \_\_\_\_\_  
snow plow hit mailbox. The box is  
damaged and does not close now.  
\_\_\_\_\_  
\_\_\_\_\_  
\_\_\_\_\_

WITNESS: Name \_\_\_\_\_  
Address \_\_\_\_\_  
Phone \_\_\_\_\_

AMOUNT OF CLAIM (damages) \$ Replace mail box

CLAIMANT'S SIGNATURE Brian Massie

**Please attach receipts, estimates, and/or other supporting data to this form.**

RETURN THIS FORM TO: KENOSHA COUNTY CLERK  
1010 - 56<sup>TH</sup> STREET  
KENOSHA WI 53140



# KENOSHA COUNTY

Regi Waligora, County Clerk

GL-08-26



## CLAIM AGAINST KENOSHA COUNTY

FULL NAME James C. Ungureanu DATE 02/25/2026

ADDRESS 730 Sheridan Rd., Apt. 103, Kenosha, WI 53104

TELEPHONE NUMBER: 608-440-3033 / j.ungureanu@gmail.com

DATE & TIME OF ACCIDENT OR LOSS Gradually over the course of 2025-2026

LOCATION OF ACCIDENT Sheridan Road, starting at 7th Ave all the way to 85th Street

DESCRIPTION OF ACCIDENT OR LOSS While traveling on Sheridan Rd, my 2017 Hyundai Elantra struck several deep and severe potholes that has been left unrepaired for over a year. The impacts caused immediate and significant steering misalignment. I am seeking reimbursement for the total cost of \$100 to restore the vehicle's alignment and repair related damage. Under Wis. Stat. 893.80, this claim is based on the municipality's failure to perform its ministerial duty to repair a "known present danger." The defect has existed for more than 12 months, providing ample constructive and actual notice to the city/county. Denying this claim would be a failure to maintain a safe roadway despite prolonged knowledge of the hazard.

WITNESS: Name \_\_\_\_\_

Address \_\_\_\_\_

Phone \_\_\_\_\_

AMOUNT OF CLAIM (damages) \$ 100.00

CLAIMANT'S SIGNATURE James C. Ungureanu 

**Please attach receipts, estimates, and/or other supporting data to this form.**

RETURN THIS FORM TO: KENOSHA COUNTY CLERK  
1010 - 56<sup>TH</sup> STREET  
KENOSHA WI 53140



# Hyundai : Elantra : 2017 : except Sport

## ExpressAlign Total Alignment

-Before Measurements

### Left Front

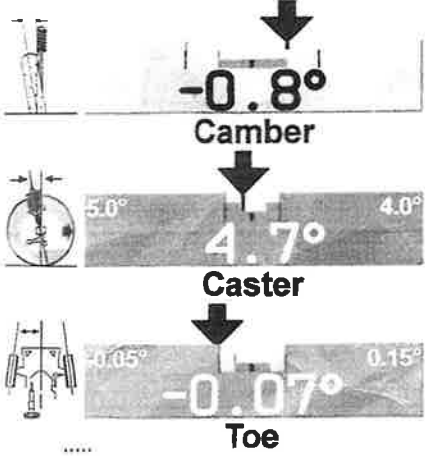

### Right Front

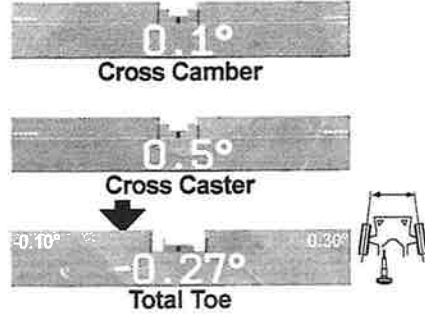
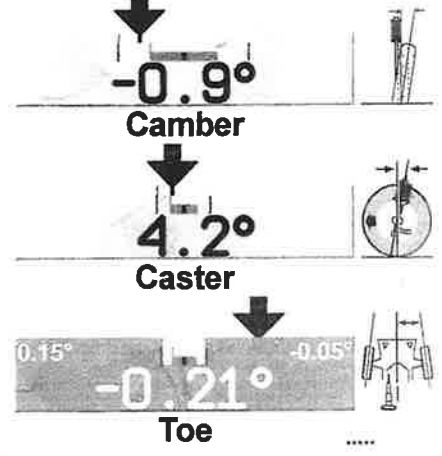

- Excessive Toe causes scuffing, shoulder wear and poor fuel economy.

### Left Rear

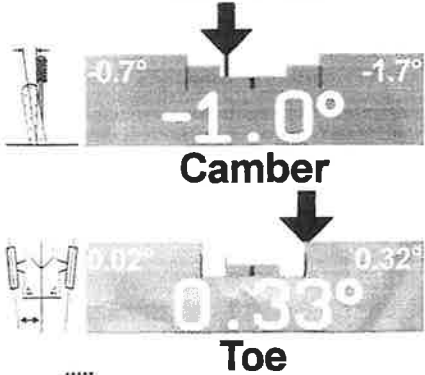

### Right Rear

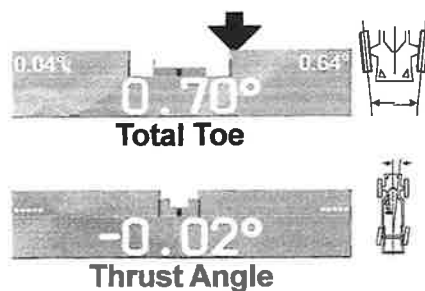
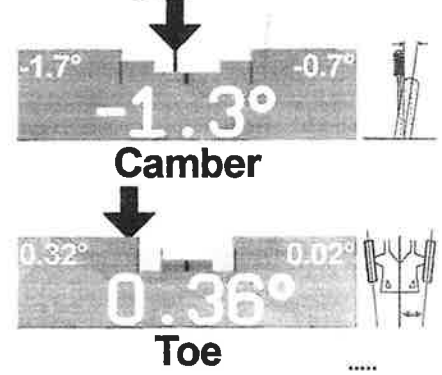

- Excessive Toe causes scuffing, shoulder wear and poor fuel economy.

